

Preface

Thank you for purchasing FR30 series vector control inverter developed and produced by FRECON.

FR30 series vector control inverter is mainly positioned for OEM customers in the middle and high-end market and specific requirements of the fan, water pump load applications, its design is flexible, embedded SVC, VF control in one, can be widely used in speed control accuracy, torque response speed, low frequency output characteristics have higher requirements for applications.

This user manual INTRODUCES THE PRODUCT features, structure features, parameter setting, operation and debugging, maintenance and inspection of FR30 series vector control inverter in detail. Please carefully read the safety precautions in this manual before use, and use the product under the premise of ensuring the safety of people and equipment.

IMPORTANT NOTES

- ◆ In order to explain the details of the product, the legend in this manual sometimes refers to the condition of removing the outer cover or safety cover.
When using this product, please be sure to install the shell or cover according to the regulations, and operate according to the contents of the manual.
- ◆ The legend in this manual is for illustration only and may be different from the product you ordered.
- ◆ The company is committed to the continuous improvement of products, product functions will continue to upgrade, the provided information is subject to change without notice.
- ◆ If you have any problem, please contact our regional agents or our customer service center.
Customer service Tel :0755-88605930.
- ◆ Please refer to our website for other product information. <http://www.freon.com.cn>

Contents

Preface	- 1 -
Contents	- 2 -
Chapter 1 Product Information	- 3 -
1.1 Nameplate information	- 3 -
1.2 Information of Product Model	- 4 -
1.3 Technical Features	- 4 -
1.4 Configuration, Mounting Dimensions and Weight	- 7 -
1.5 Product terminal configuration	- 9 -
Chapter 2 Keyboard operation guide	- 12 -
2.1 Operation and display	- 16 -
2.2 Key function introduction	- 17 -
2.3 Introduction to the keyboard menu structure	- 18 -
2.4 LCD keyboard menu	- 19 -
2.5 Inverter parameter menu	- 19 -
2.6 Operating instructions	- 20 -
Chapter 3 List of Parameter	- 24 -
Chapter 4 Maintenance and Troubleshooting	- 59 -
Appendix A: Modbus Communication Protocol	- 64 -
Appendix B: Braking Resistor	- 68 -
Appendix C: Peripheral Device Selection	- 69 -
Appendix D: Keyboard Dimensions	- 70 -

Chapter 1 Product Information

1.1 Nameplate information



Model Explanation

Model show on product nameplate contains information below.

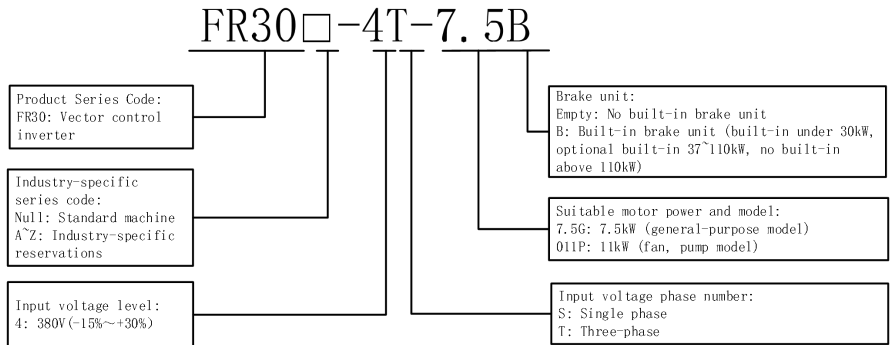

1.2 Information of Product Model

Model No.	Power capacity KVA	Rated Input current (A)		Rated output current (A)		Applicable motor	
		Heavy load	Light load	Heavy load	Light load	kW	HP
Three-phase power supply: 380V, 50/60Hz Range: -15%~+30%							
FR30-4T-0.7B-H	1.5	0.9	1.7	1.5	2.5	0.75	1
FR30-4T-1.5B-H	3	1.7	3.1	2.5	4.2	1.5	2
FR30-4T-2.2B-H	4	3.1	4.5	4.2	5.5	2.2	3
FR30-4T-3.0B-H	4.8	4.5	6.0	5.5	7.5	3.0	4
FR30-4T-4.0B-H	6	6.0	8	7.5	9.5	4.0	5
FR30-4T-5.5B-H	8.9	8	10.5	9.5	13	5.5	7.5
FR30-4T-7.5B-H	11	10.5	14.1	13	17	7.5	10
FR30-4T-011B-H	17	14.1	20.6	17	25	11	15
FR30-4T-015B-H	21	20.6	27.7	25	32	15	20
FR30-4T-018B-H	24	27.7	34.1	32	37	18.5	25
FR30-4T-022B-H	30	34.1	40.5	37	45	22	30
FR30-4T-030B-H	40	40.5	54.8	45	60	30	40
FR30-4T-037(B)-H	57	54.8	67.1	60	75	37	50
FR30-4T-045(B)-H	69	67.1	81.4	75	91	45	60
FR30-4T-055(B)-H	85	81.4	98.9	91	112	55	70
FR30-4T-075(B)-H	114	98.9	134.3	112	150	75	100
FR30-4T-090(B)-H	134	134.3	170	150	176	90	125
FR30-4T-110(B)-H	160	170	201	176	210	110	150
FR30-4T-132-H	192	201	237	210	253	132	175
FR30-4T-160-H	231	237	284	253	304	160	210

1.3 Technical Features

Project		Specifications
Power input	Rated input voltage (V)	3-phase 380 V (-15% ~ +30%)
	Rated input current (A)	See 1.2
	Rated input frequency (Hz)	50Hz/60Hz, tolerance±5%
Power output	Applicable motor(kW)	See 1.2
	Rated output current (A)	See 1.2
	The maximum output voltage (V)	0 ~ rated input voltage, error<±3%
	The maximum output frequency (Hz)	0.00 ~ 590.00 Hz,unit0.01Hz
Control characteristics	V/F patterns	V/F control Sensor-less vector control 1 Sensor-less vector control 2 Close loop vector control with PG card

Project		Specifications
	Speed range	1:50 (V/f control) 1:100 (sensor-less vector control 1) 1:200 (sensor-less vector control 2) 1:1000 (VC with PG card)
	Speed accuracy	±0.5% (V/F control) ±0.3% (sensor-less vector control 1 & 2)
	Speed fluctuation	±0.3% (sensor-less vector control 1 & 2)
	Torque response	< 10ms (sensor-less vector control 1 & 2)
	Starting torque	0.5Hz: 180% (V/f control, sensor-less vector control 1) 0.25Hz: 180% (sensor-less vector control 2)
	Basic functions	Carrier frequency
Overload capability		G Model:150% Rated Current 60s,180% Rated Current 10s,200% Rated Current 1s. P Model:120% Rated Current 60s,145% Rated Current 10s,160% Rated Current 1s.
Torque boost		Automatic torque boost; Manual torque boost 0.1% ~ 30.0%
V/F Curve		Three ways: straight; multi-point type; N Th-type V / F curve(1.2 Th -type, 1.4 Th -type, 1.6 Th -type, 1.8 Th -type, 2 Th -type)
Acceleration and deceleration Curve		Line or curve acceleration and deceleration mode. Four kinds of acceleration and deceleration time, Ramp Time Range :0.0 ~ 6000.0s
DC brake		DC brake start frequency: 0.00 ~ 590.00Hz DC brake time:0.0s ~ 10.0s DC brake current:0.0% ~ 150.0%
Basic functions	Jog brake	Jog frequency range:0.00Hz ~ 50.00Hz. Jog deceleration time: 0.0s ~ 6000.0s.
	Simple PLC, Multi-speed	Through the built-in PLC or control terminal to achieve up to 16 speed running
	Built-in PID	Facilitate the realization of process control loop control system
	Automatic voltage adjustment (AVR)	When the grid voltage changes, can automatically maintain a constant output voltage
	Fast current limit function	Minimize over current fault protection inverter running
	Over voltage Over current	System automatically limits of current and voltage during operation to prevent frequent
Run	Command source	Given the control panel, control terminal, serial communication port given.
	Frequency given	9 kinds of frequency sources: digital setting, keyboard potentiometer setting, analog Voltage, given analog current reference pulse is given, the serial port is given, multi-speed given, PLC is given, the process PI D reference. There are several ways to switch
	Input terminal	7 Switch input terminals, one way to make high-speed pulse input. 3-channel analog inputs, including 2-way 0 ~ 10V / 0 ~ 20mA voltage and current options, a way to support -10 ~ +10 V input

Project		Specifications
	output terminal	2-way switch output terminal, which supports a maximum road speed 100kHz pulse output. 2 relay output terminals. 2 analog output terminal, and optional voltage and current.
Featured functions		Parameter copy, parameter backup, flexible parameter displayed & hidden. Common DC bus (Contains below 30 KW) . Various master & auxiliary command and switchover. Reliable speed search started. A variety of Accel / Decel curves programmable. Timing control, fixed length control, count function. Three faults recorded. Over excitation brake, overvoltage stall protection programmable, under voltage stall protection programmable, restart upon power loss. Four kinds of Accel/Decel time. Motor thermal protection. Flexible fan control. Process PID control, simple PLC, 16-step speed control programmable. Wobble frequency control. Multi-functional key programmable, field-weakening control. High-precision torque control, V/f separated control, torque control at sensor-less vector control.
Protection function		Provide fault protection dozen:Overcurrent, Overvoltage, Undervoltage, Overtemperature, Overload Etc Protection.
Display and keyboard	LCD Display	Display Parameters
	Key lock and function selection	Realize some or all of the keys locked, scope definition section keys to prevent misuse
	Run and stop monitoring information	In the run or stop can be set to monitor U00 group four objects were.
Environment	Place of operation	Indoors, no direct sunlight, free from dust, corrosive gases, flammable gases, oil mist, water vapor, water drop and salt, etc.
	Altitude	0 ~ 2000m De-rate 1% for every 100m when the altitude is above 1000 meters
	Ambient temperature	-10°C ~ 40°C
	Relative humidity	5 ~ 95%, no condensation
	Vibration	Less than 5.9m/s ² (0.6g)
	Storage temperature	-20°C ~ +70°C
Others	Efficiency	Rated power≥93%
	Installation	Wall-mounted or Flange mounting
	IP grade	IP20
	Cooling method	Fan cooled

1.4 Configuration, Mounting Dimensions and Weight

◆5.5-7.5KW Dimensions and wall mounting dimensions:

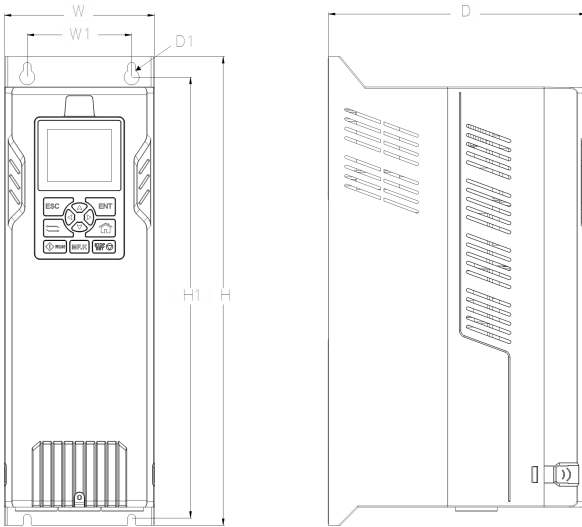

Type	Inverter model	Shape and installation size (mm)						weight (Kg)	structure type
		W	W1	H	H1	D	D1		
Three-phase power supply: 380V, 50/60Hz Range: -15%~+30%									
T1	FR30-4T-0.7B-H								plastic
	FR30-4T-1.5B-H								
	FR30-4T-2.2B-H								
	FR30-4T-3.0B-H								
	FR30-4T-4.0B-H								
T2	FR30-4T-5.5B-H	125	87	385	371	214	6.5	5.34	plastic
	FR30-4T-7.5B-H								

◆11-75KW Dimensions and wall mounting dimensions:

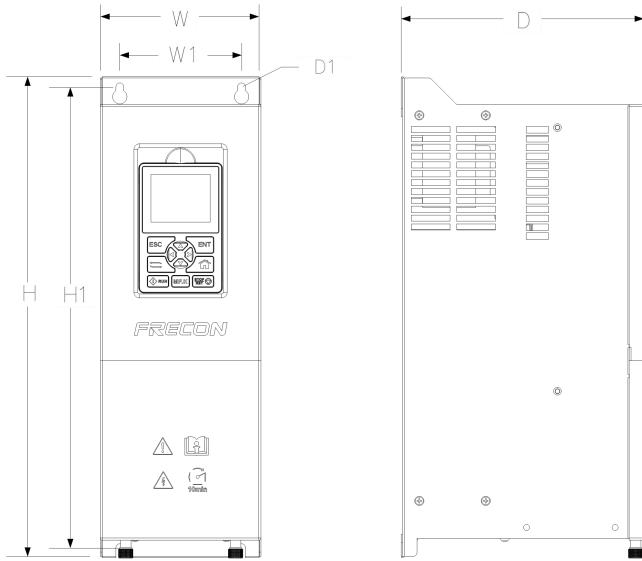

Type	Inverter model	Shape and installation size (mm)						weight (Kg)	structure type
		W	W1	H	H1	D	d		
Three-phase power supply: 380V, 50/60Hz Range: -15%~+30%									
T3	FR30-4T-011B-H FR30-4T-015B-H	145	110	423	416	220	6.5	14	Sheet metal
T4	FR30-4T-018B-H FR30-4T-022B-H FR30-4T-030B-H	195	150	485.4	470	232	7.0	19	Sheet metal
T5	FR30-4T-037(B)-H FR30-4T-045(B)-H	210	150	588.4	570	258	7.0	23	Sheet metal
T6	FR30-4T-055(B)-H FR30-4T-075(B)-H	250	200	550	534	368.8	6.5	31.54	Sheet metal
T7	FR30-4T-090(B)-H FR30-4T-110(B)-H								Sheet metal
T8	FR30-4T-132-H FR30-4T-160-H								Sheet metal

1.5 Product terminal configuration

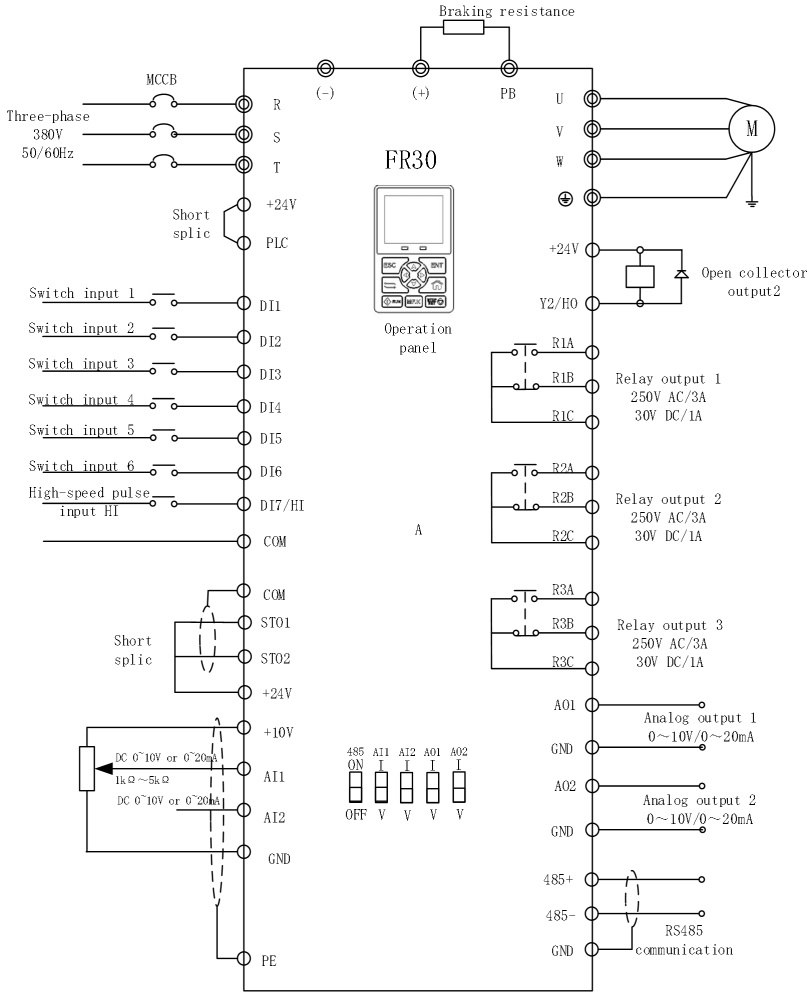

(1) Main circuit terminals discription

Terminal marks	Designation and function of terminals.
R, S, T	AC power input terminals for connecting to 3-phase AC380V power supply.
U, V, W	AC output terminals of inverter for connecting to 3-phase induction motor.
(+), (-)	Positive and negative terminals of internal DC bus.
PB	Positive and negative terminals of internal DC bus. Connecting terminals of braking resistor. One end connected to + and the other to PB.
	Grounding terminal.

Remarks: No phase sequence requirements on wiring of the input side of inverter. Wiring

(2) Contrl circuit terminals discription

Type	Terminal	Name	Function Description
Power supply	+10V-GND	External +10 V power supply	Provide +10 V power supply to external unit. Generally, it provides power supply to external potentiometer with resistance range of 1–5 k Ω . Maximum output current: 10 mA
	+24V-COM	External +24V power supply Applying to Overvoltage Category II circuit	Provide +24 V power supply to external unit. Generally, it provides power supply to DI/Do terminals and external sensors. Maximum output current: 200 mA (GND below 4.0kW)
	PLC	Input terminal of external power supply	Connect to +24 V by default. When DI1-DI7 need to be driven by external signal, PLC needs to be connected to external power supply and be disconnected from +24 V.
Analog input	AI1-GND	Analog input 1	Input voltage range:DC 0 ~ 10V/0 ~ 20mA, decided by toggle switches AI1, AI2 on the control board Impedance: 250 k Ω (voltage input), 250 Ω (current input)
	AI2-GND	Analog input 2	
	AI3-GND	Analog input 3	Input Voltage Range:DC -10 ~ +10V Input impedance:250k Ω
Switch input	DI1- COM	Switch input terminals 1	Maximum input frequency:200Hz Impedance:2.4k Ω Voltage range for level input:9V ~ 30V (GND below 4.0kW)
	DI2- COM	Switch input terminals 2	
	DI3- COM	Switch input terminals 3	
	DI4- COM	Switch input terminals 4	
	DI5- COM	Switch input terminals 5	
	DI6- COM	Switch input terminals 6	

Type	Terminal	Name	Function Description
	DI7/HI-COM	Switch input terminals 7 OR High-speed pulse input	Besides features of DI1–DI6, it can be used for high-speed pulse input. Maximum input frequency: 100 kHz
Analog output	AO1-GND	Analog output terminal 1	Output voltage range:DC 0 ~ 10V/0 ~ 20mA, decided by toggle switches
	AO2-GND	Analog output terminal 2	AO1, AO2 on the control board Impedance requirements \geq 10k Ω
Switch output	Y1-COM	Open collector output 1	Voltage range:0 ~ 24V Current range:0 ~ 50mA
	Y2/HO-COM	Open collector output 2 OR High-speed pulse output	Besides features of Y1, it can be used for High-speed pulse output channels. The maximum output frequency:100kHz
Relay output	R1A/R1B/R1C	RA-RC normally open terminals RB-RC normally closed terminals	Contact driving capacity: AC250V, 3A, COS ϕ =0.4. DC 30V, 1A
	R2A/R2B/R2C		
	R3A/R3B/R3C		
485 Communication	485+ -485-	485 Communication Terminals	Rate: 4800/9600/19200/38400/57600/115200bps Termination resistor is set by the toggle switch on the control panel RS485
	GND	485 Communication shielded ground	
STO	STO1	STO channel 1	Internal: factory STO1, STO2 are connected with +24V short splices by default; External: STO1, STO2, +24V can be externally led to the external 24V power supply, and the specific wiring can refer to STO related functions.
	STO2	STO channel 2	
	+24V	STO channel 1/2 power supply+	
	COM	STO channel 1/2 power ground	
Shield	PE	Shield Ground	Ground terminal for shield
Auxiliary Interface		External operation panel interface	Use standard network cable Maximum cable distance: 50m

Chapter 2 Installation and Wiring

2.1 Installation Environment

- 1) Ambient temperature in the range of $-10^{\circ}\text{C} \sim 50^{\circ}\text{C}$.
- 2) Drive should be installed on surface of flame retardant object, with adequate surrounding space for heat dissipation.
- 3) Installation should be performed where vibration is less than 5.9m/s^2 (0.6g).
- 4) Avoid from moisture and direct sunlight.
- 5) Protect the cooling fan by avoiding oil, dust and metal particles;
- 6) Do not expose to an atmosphere with flammable gases, corrosive gases, explosive gases or other harmful gases.
- 7) Prevent drilling residues, wire ends and screws falling into drive.
- 8) Ventilation part of the drive should be installed outside from harsh environment (e.g. Textile facilities with fiber particles and chemical facilities filled with corrosive gases or Loaded dust cover).

2.2 Installation Direction, Space and Cooling

A fan is integrated in FR30 for forced air cooling. FR30 has to be installed vertically for the purpose of good cooling circulation. Sufficient spaces have to be left between FR30 and its peripheral objects. Multi- FR30 can be installed in parallel horizontally e and vertically. See followings for specific space requirement, heat dissipating capacity and mass airflow.

2.2.1 Single installation

Wall mounted installation diagram :

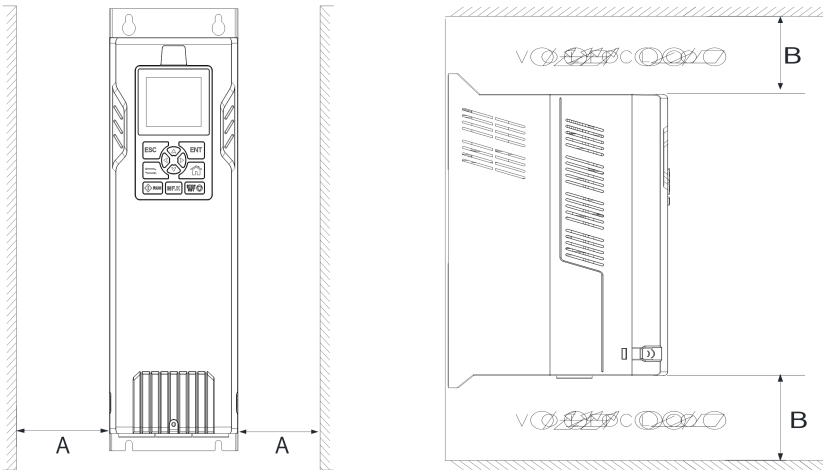

2.2.2 Multiple installations

Multiple parallel installations:

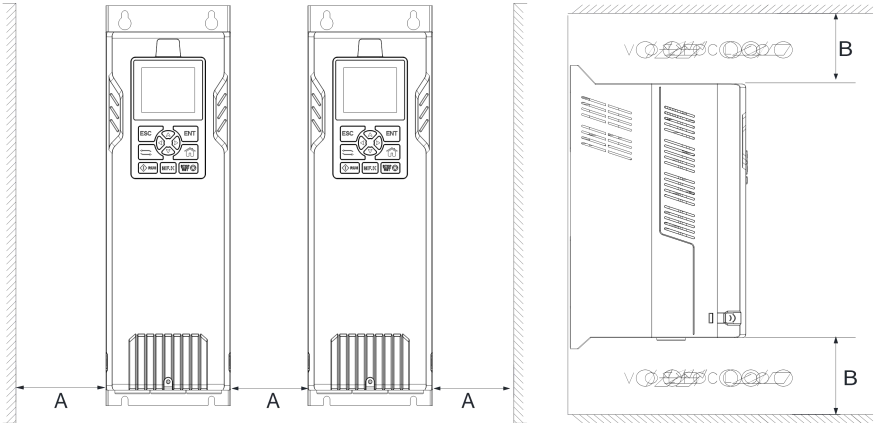

Drive model	Mounting clearances (mm)	
	A	B
4~15kW	≥50	≥100
18~45kW	≥50	≥200
≥55kW	≥150	≥300



2.3 Fixed manner

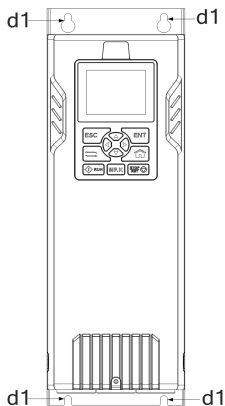

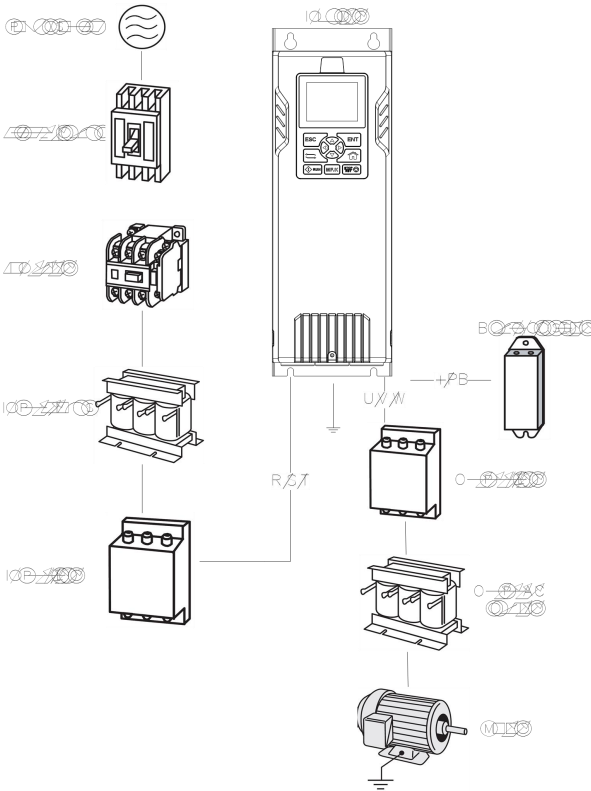

Wall mounting dimensions refer to Chapter 1 (session 1.4) , As shown in Fig drilling four holes in the mounting surface. Put the inverter against the panel and mate 4 holes, and then tighten screws in the 4 holes tighten any of the 2 screws in diagonal position, tighten 4 holes with screws for strengthened installation



2.4 Configuration of Peripheral Devices



Picture	Device	Instructions
	Cable	Transmitting electrical signals.
	Circuit breaker	Purpose: disconnect power supply and protect the equipments in case of abnormal overcurrent occurs Type selection: breaking current of circuit breaker is defined to be 1.5~2 times the rated current of the drive Breaking time characteristic of circuit breaker should be selected based on overload protection time characteristic of the drive
	Input chokes	Improve power factor Reduce the impact of imbalanced three-phase input AC power supply on the system Suppress higher harmonics and reduce the conducted and radiated interference to peripheral devices Restrict the impact of impulse current on rectifier bridges

Picture	Device	Instructions
	Input filter	Reduce conducted interference from power supply to the drive, improve the immunity of the drive from noise Reduce conducted and radiated interference of the drive to peripheral device
	Braking resistor	Purpose: consume motor feedback energy to attain quick brake
	Output filter	Output filter and radiated interference of the drive to peripheral devices
	Output AC reactor	Avoid the motor insulation damage result from harmonic voltage Reduce frequent protection from the drive caused by leakage current In case the cable connecting drive and motor is over 50 meters, output AC reactor recommended

2.4.1 Selection of Peripheral Devices

Model.NO	Circuit breaker (A)	Contactors (A)	Power terminals Cable Specifications (mm ²)	Ground terminal cable specifications (mm ²)	Terminal screws Specifications
3-Phase:380V, 50/60Hz Range:-15%~+30%					
FR30-4T-5.5B-H	40	32	4.0	4.0	M4
FR30-4T-7.5B-H	63	40	6.0	6.0	M4
FR30-4T-011B-H	63	40	6.0	6.0	M5
FR30-4T-015B-H	100	63	10	10	M5
FR30-4T-018B-H	100	63	10	10	M5
FR30-4T-022B-H	100	63	16	10	M6
FR30-4T-030B-H	160	100	16	16	M6
FR30-4T-037B-H	200	125	25	16	M8
FR30-4T-045B-H	200	125	35	25	M8
FR30-4T-055B-H	250	160	50	25	M10
FR30-4T-075B-H	250	160	70	35	M10

Chapter 3 Keyboard operation guide







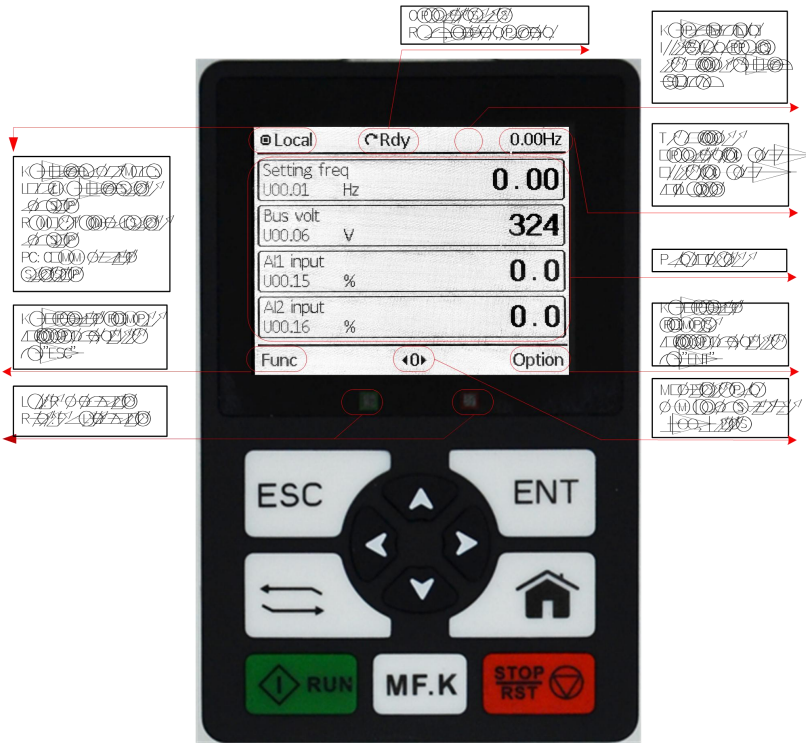







3.1 Operation and display

Key presses/display instructions

The keyboard size is the same as the standard digital tube keyboard, so the keyboard is compatible with the FR500 keyboard model.



3.2 Key function introduction

keystroke	name	description
	Return key (ESC)	Back key/Home to enter the parameter menu button
	Confirm key (ENT)	Enter the next level menu / parameter modification confirmation / enter the LCD menu interface
	Shortcut Key (QUICK)	When on the home page, you can quickly enter the shortcut menu interface
	Home Key (HOME)	Used to quickly return to the home page
	Multifunction keys (MF.K)	Used with function code F16.00, the default is jog button
	Up arrow (UP)	Option increment / parameter modification
	Down arrow (DOWN)	Option decrement/parameter modification
	Left arrow (<)	Parameter shift
	Right arrow (>)	Parameter shift
	Run key (RUN)	Used to start the keyboard when the keyboard starts and stops.
	Stop key (STOP)	1. When the keyboard starts and stops, it is used for keyboard stopping 2. In case of failure, it is used for fault reset
	Key combinations 1	When the run key and the stop button are pressed at the same time, the drive stops freely
	Key combinations 2	When the ESC and ENT keys are pressed at the same time, the user password and keypad lock functions take effect immediately (not 0 in the presence of user password and F16.02)
	Key combinations 2	When the keyboard is locked, press the ESC and > keys at the same time to unlock the keyboard

3.3 Introduction to the keyboard menu structure

This section is mainly used to introduce the structure of the menu, please see Chapter 3 for detailed instructions.

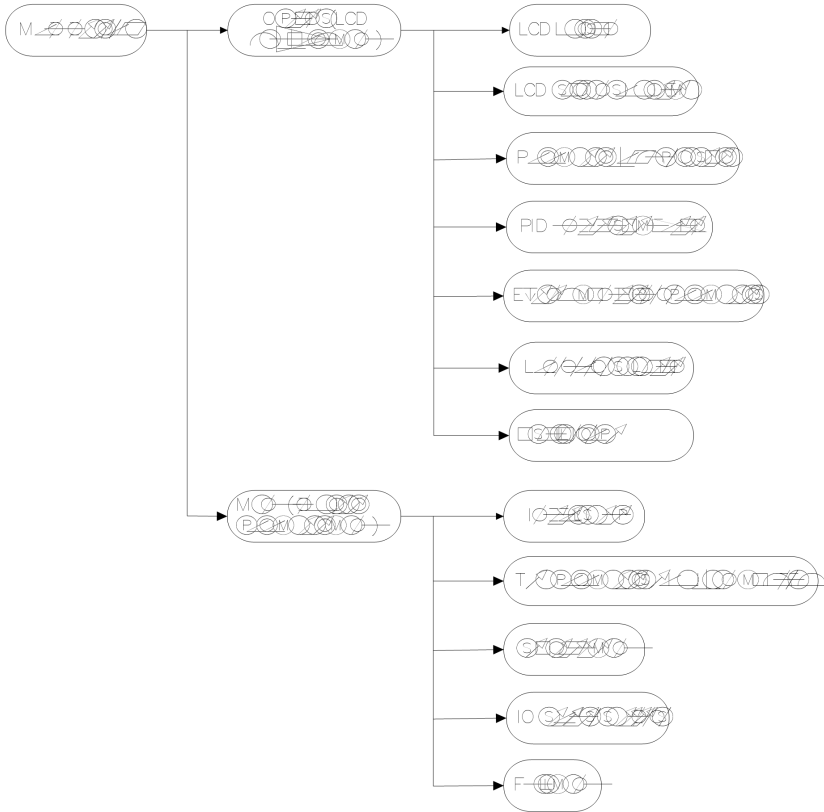

3.4 LCD keyboard menu



► **【00】 LCD version**

Displays the current LCD software version and the version upgrade time.

► **【01】 LCD screensaver time**

If the time is not 0, there is no key operation and the backlight turns off after the set time is reached. When the screen is off, press any key to resume.

► **【02】 Parameter backup**

It can be used to backup/restore inverter parameters, up to 3 copies can be backed up, detailed operation steps see the next chapter.

► **【03】 PID unit selection**

Available for custom PID units.

► **【04】 Extend monitoring parameters**

The default monitoring parameters of the home page are 3 pages, of which the parameters on page 0 are determined by the F16 group, and 1~2 are set in "[04] Extended Monitoring Parameters", which can be extended to up to 6 pages. 详细的操作Step to see the next chapter.

► **【05】 Language selection**

It can be used to set the language of LCD display, built-in 3 language selections (Chinese/English/Turkish). For detailed steps, see the next section.

► **【06】 oscillograph**

It can be used to monitor the change of some parameter curves in group U. For detailed steps, see the next section.

3.5 Inverter parameter menu

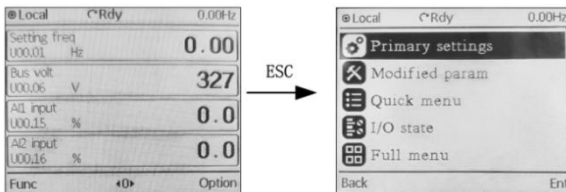

► **Initial setup**

Basic setup menu before the drive starts. See the next section for more information.

► **The parameters have been modified**

It is used to display the function code that is different from the factory value, and there is a waiting time when entering. (Older versions of Control do not support this feature)

► **shortcut menu**

Display the user menu, users can add commonly used function codes in the shortcut menu interface

(Fxx.xx parameter interface), and then press the button  on the home page to enter the shortcut menu interface.

► **I/O Status & Settings**

This interface can be used to display the status of the current I/O port and the corresponding IO port function settings.

► **Full menu**

Displays all function codes of the frequency converter

3.6 Operating instructions

This section is for detailed instructions.

3.6.1 Parameter backup/restore

► **Parameter backup:**

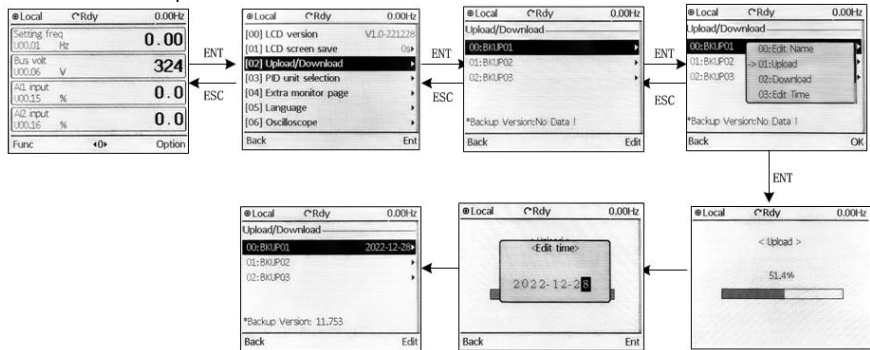

► **Parameter recovery:**

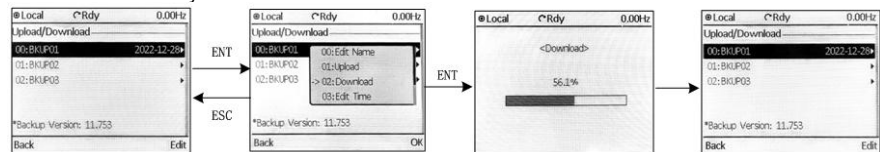

3.6.2 Extended monitoring parameter settings

Change the first item "U00.00" of the monitoring page "1" to "U00.04":

This interface can be enabled or not by moving the right key (>)

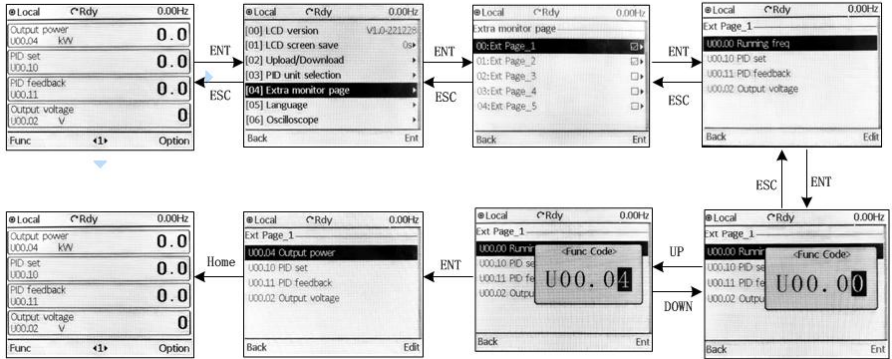

3.6.3 oscillograph

► Run the oscilloscope

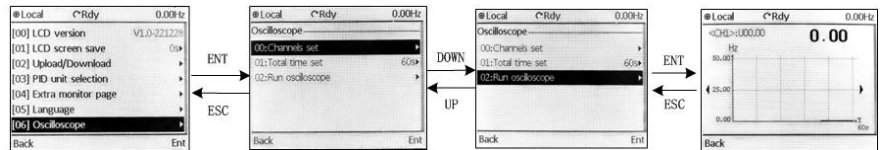

► Oscilloscope channel settings

Eg: Change Channel 1 (CH1: U00.00) to (CH1:U00.04)

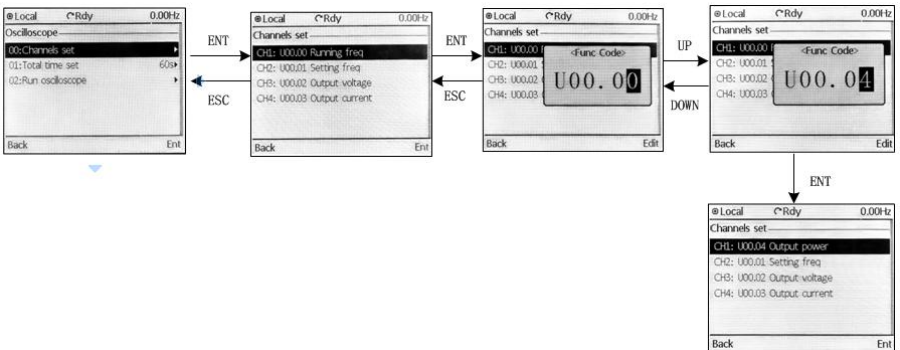

► Oscilloscope channel switching display

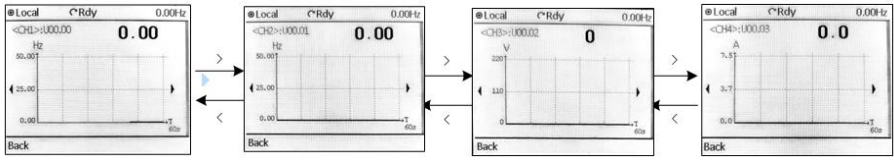

3.6.4 Initial setup

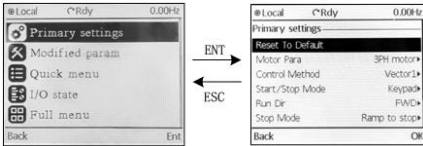

Depending on how the frequency is given, the options after "Frequency Given By" will be different.

3.6.5 shortcut menu

Shortcut menus are intended primarily for easy use in setting common parameters.

► Enter the shortcut menu interface

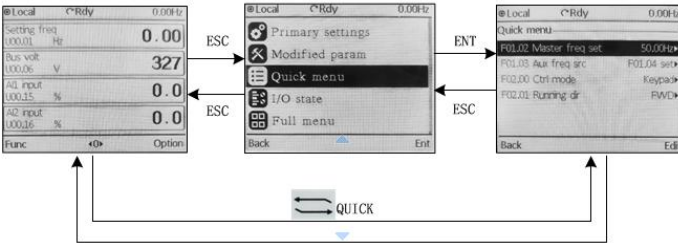

► Add shortcut parameters

1) Method 1: Press the right-shift key (>) on the shortcut menu interface to add

Select the function code to be added by pressing the up and down left and right keys

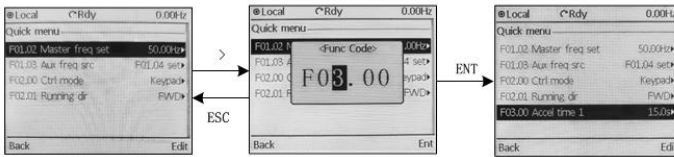

2) Method 2: Press the right shift key and the left shift key (<>) at the same time in the Fxx.xx interface to add

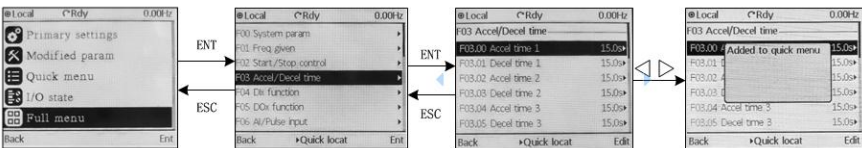

Chapter 4 List of Parameter

Group F00 ~ F22 are standard function parameters. Group U00 is status monitoring parameters.

Group U01 is fault record parameters.

The symbols in the function code table are described as follows:

"△" means the value of this parameter can be modified in stop and running status of drive;

"x" means the value of this parameter cannot be modified when drive is running;

"⊙" means this parameter is a measured value that cannot be modified;

Default: The value when restored to factory default. Neither measured parameter value nor recorded value will be restored.

Setting Range: the scope of setting and display of parameters

FR30 parameter groups are listed below:

Category	Parameter Group
System Parameters	F00: System Parameters
Basic Parameters	F01: Frequency Command
	F02: Start/Stop Control Start/Stop Control
	F03: Accelerate/Decelerate Parameters
Input & Output Terminals	F04: Digital Input
	F05: Digital Output
	F06: Analog and Pulse Input
	F07: Analog and Pulse Output
	F22: Virtual IO
Motor and Control 1Parameters	F08: Parameters of Motor 1
	F09: V/f Control Parameters of Motor 1
	F10: Vector Control Parameters of Motor 1
Protection Parameters	F11: Protection Parameters
Application Parameters	F12: Multi-Reference and Simple PLC Function
	F13: Process PID
	F14: Swing Frequency, Fixed Length ,Count and Wakeup
Communication Parameters	F15: Communication Parameters
Keys and Display of Keypad Parameters	F16:Keys and Display of Keypad Parameters
User-defined Display Parameters	F17:User-defined Display Parameters
Motor and Control 2Parameters	F18: Motor 2 basic parameters
	F19: Motor 2VF control parameters
	F20: Motor 2 vector control
	F21: Position contro
Monitoring Parameters	U00:Status monitoring
	U01:Fault record

Param.	Parameter Name	Setting Range	Default	Attr
Group F00: System Parameters				
F00.00	Setting of User Password	0 ~ 65535	0	×
F00.01	Display of Parameters	0: Display all parameters 1: Only display F00.00, F00.01 and user-defined parameters 2: Only display F00.00, F00.01, and the parameters different with factory default	0	×
F00.02	Parameter Protection	0: All parameter programmable 1: Only this function code is allowed to be modified	0	×
F00.03	Inverter model selection	0: G type (Constant torque load model) 1: P type (Fan and pump load models)	0	×
F00.04	Parameter Initialization	0: No operation 1: Restore all parameters to factory default (excluding motor parameters) 2: Clear fault record 3: Back up current user parameters 4: Restore user backup parameters 5: Restore factory default. (include motor parameter) 6: Power consumption zero clearing	0	×
F00.06	Parameter editing mode	0: Editable via keypad and RS485. 1: Editable via keypad 2: Editable via RS485	0	×
F00.07	Motor selection	0: Motor 1 1: Motor 2	0	×
F00.08	Motor 1 control mode	Unit's place: Motor 1 control mode 0: V/F control 1: Sensor-less vector control 1 2: Sensor-less vector control 2 3: Vector control with PG card Ten's place: Motor 2 control mode 0: V/F control 1: Sensor-less vector control 1 2: Sensor-less vector control 2 3: Vector control with PG card	1	×
F00.09	DI7/HI input mode	0: Digital input terminal 7 1: Pulse input	0	×
F00.10	AI1/AI2/AI3 input mode	Unit's place: AI1 0: Analog input 1: Digital input Ten's place: AI2 (same as AI1) Hundred's place: AI3 (same as AI1)	000	×
F00.11	Y2/HO input mode	0: Digital Output terminal 2 1: Pulse output	0	×

Param.	Parameter Name	Setting Range	Default	Attr
F00.12	PWM optimization	Unit's place: PWM modulation mode 0: Fixed carrier 1: Random carrier 2: Derating of fixed carrier 3: Derating of random carrier	500	×
		Ten's place: PWM modulation mode 0: Seven-segment mode 1: Five-segment mode 2: Five-segment and seven-segment automatic switchover		
		Hundred's place: over-modulation coefficient 0: Invalid 1~9: 1.01~1.09 times of over-modulation		
F00.13	Carrier frequency	0.700 ~ 16.000kHz	Model defined	△
F00.14	Upper carrier frequency	0.700 ~ 16.000kHz	8.000kHz	×
F00.15	Lower carrier frequency	0.700 ~ 16.000kHz	2.000kHz	×
F00.16	Output voltage	5.0 ~ 150.0%	100.0%	×
F00.17	AVR	0: Disabled	1	×
		1: Enabled		
		2: AVR is disabled if the DC bus voltage > the rated voltage of DC bus, and it will be enabled if the DC bus voltage ≤ the rated voltage of DC bus.		
F00.18	Fan control	0: Run at power-on	1	×
		1: Fan working during running		
F00.19	Factory password	0 ~ 65535	0	×
F00.20	Inverter rated power	0.2 ~ 1000.0kW	Model defined	○
F00.21	Inverter rated voltage	60 ~ 660V	Model defined	○
F00.22	Inverter rated current	0.1 ~ 1500.0A	Model defined	○
F00.23	Software version	0.00 ~ 655.35	Model defined	○
F00.24	Dealer password	0 ~ 65535	0	×
F00.25	Run time setting	0 ~ 65535h(0: Invalid)	0h	×
Group F01: Frequency Command				
F01.00	Frequency source selection	0: Master frequency source	0	×
		1: Auxiliary frequency source		
		2: Master +Auxiliary		
		3: Master - Auxiliary		
		4: MAX{Master, Auxiliary }		
		5: MIN {Master, Auxiliary }		
6: AI1(Master + Auxiliary)				

Param.	Parameter Name	Setting Range	Default	Attr
		7: AI2(Master +Auxiliary)		
F01.01	MasterFrequency Command Source	0:Master digital setting (F01.02)	1	×
		1: keypad potentiometer		
		2: Analog input AI1		
		3: Communication		
		4: Multi-reference		
		5: PLC		
		6: Process PID output		
		7: X7/HI pulse input		
		8: AI2		
		9: AI3		
F01.02	Master Frequency Digital setting	0.00 ~ Fmax	50.00Hz	△
F01.03	Auxiliary Frequency Command Source	0: Auxiliary digital setting (F01.04)	0	×
		1: keypad potentiometer		
		2: Analog input AI1		
		3: Communication		
		4: Multi-reference		
		5: PLC		
		6: Process PID output		
		7: X7/HI pulse input		
		8: Analog input AI2		
		9: Analog input AI3		
F01.04	Auxiliary frequency digital setting	0.00 ~ Fmax	50.00Hz	△
F01.05	Auxiliary frequency range	0: Relative to maximum frequency	0	×
		1: Relative to master frequency		
F01.06	Auxiliary frequency coeff	0.0 ~ 150.0%	100.0%	△
F01.07	Jog frequency	0.00 ~ Fmax	5.00Hz	△
F01.08	Maximum frequency	20.00 ~ 590.00Hz	50.00Hz	×
F01.09	Upper limit frequency	Fdown ~ Fmax	50.00Hz	×
		Lower limit frequency ~ maximum frequency		
F01.10	Lower limit frequency	0.00 ~ Fup	0.00Hz	×
F01.11	Operation when command frequency lower than lower limit frequency	0: Run at lower limit frequency	0	×
		1: Run at 0 Hz would be activated after the time delay set by F01.12		
F01.12	Lower limit frequency running time	0.0 ~ 6000.0s	60.0s	×
F01.13	Up to this frequency, start frequency compensation	0.00~590.00Hz	50.00Hz	△
F01.14	Frequency compensation per 50Hz	0.00~50.00Hz	0.00Hz	△
Group F02: Start/Stop Control				
F02.00	Run command	0: Keypad control (LED off)	0	×
		1: Terminal control (LED on)		
		2: Communication control (LED blinking)		

Param.	Parameter Name	Setting Range	Default	Attr
F02.01	Running direction	0: Forward	0	△
		1: Reverse		
F02.02	Reverse-proof action	0: Reverse enabled	0	×
		1: Reverse disabled		
F02.03	Dead time between forward and reverse	0.0 ~ 6000.0s	0.0s	×
F02.04	Start mode	Unit's place: Start Mode 0: Start directly 1: Rotational speed track and restart	30000	×
		Ten's place: short-circuit detection function 0: Ungrounded short-circuit detection 1: Grounding short-circuit detection before the first starts 2: Grounding short-circuit detection before each starts		
		Hundred's place: Speed tracking 0: Track from zero speed 1: Track from max frequency		
		Thousand's place: Select if Jog function takes the priority 0: Disable 1: Enable		
		Ten thousand's place: Tracking direction 0: Last direction when stop 1: Positive direction 2: Negative direction 3: Starting direction		
F02.05	Start frequency	0.00 ~ 10.00Hz	0.00Hz	×
F02.06	Startup frequency holding time	0.0 ~ 100.0s	0.0s	×
F02.07	Startup DC braking current	0.0 ~ 150.0%	0.0%	×
F02.08	DC braking time at start	0.0 ~ 100.0s	0.0s	×
F02.09	Speed search current	0.0 ~ 180.0%	130.0%	△
F02.10	Sped search decel time	0.0 ~ 10.0s	1.0s	×
F02.11	Sped search coefficient	0.01 ~ 5.00	0.30	△
F02.12	Stop mode	0: Ramp to stop	0	×
		1: Coast to stop		
F02.13	Initial frequency of stop DC braking	0.01 ~ 50.00Hz	2.00Hz	×
F02.14	Stop DC braking current	0.0 ~ 150.0%	0.0%	×
F02.15	Waiting time of stop DC braking	0.0 ~ 30.0s	0.0s	×
F02.16	Stop DC braking time	0.0 ~ 30.0s	0.0s	×

Param.	Parameter Name	Setting Range	Default	Attr
F02.17	Dynamic brake	0: Disabled	0	×
		1: Enabled		
		2: Enabled at running		
		3: Enabled at deceleration		
F02.18	Voltage ofdynamic braking	480 ~ 800V(380V inverter)	730V	×
		280 ~ 400V(220V inverter)	350V	
F02.19	Brake use ratio	5.0 ~ 100.0%	100.0%	×
F02.20	0Hz output selection	0: No voltage output	0	×
		1: Voltage output		
F02.21	Auto-start of power-on again	0: Invalid	0	△
		1: Valid		
F02.22	Waiting time between auto-start and power-on again	0.0~10.0s	0.5s	△
Group F03: Accel/Decel Parameters				
F03.00	Accel time 1	0.0 ~ 6000.0s	Model confirmed	△
F03.01	Decel time 1	0.0 ~ 6000.0s	Model confirmed	△
F03.02	Accel time 2	0.0 ~ 6000.0s	15.0s	△
F03.03	Decel time 2	0.0 ~ 6000.0s	15.0s	△
F03.04	Accel time 3	0.0 ~ 6000.0s	15.0s	△
F03.05	Decel time 3	0.0 ~ 6000.0s	15.0s	△
F03.06	Accel time 4	0.0 ~ 6000.0s	15.0s	△
F03.07	Decel time 4	0.0 ~ 6000.0s	15.0s	△
F03.08	Jog accel time	0.0 ~ 6000.0s	15.0s	△
F03.09	Jog decel time	0.0 ~ 6000.0s	15.0s	△
F03.10	Accel/Decele curve	0: Linear Accel/Decel	0	×
		1: S-curve Accel/Decel		
F03.11	Initial segment time of acceleration of S curve	0.0 ~ 6000.0s	0.0s	×
F03.12	Time unit of acceleration and deceleration	0: 0.1s	0	×
		1: 0.01s		
F03.13	Frequency switchover pointbetween acceleration time 1and acceleration time 2	0.00 ~ Fmax	0.00Hz	×
F03.14	Frequency switchover pointbetweendeceleration time 1and deceleration time 2	0.00 ~ Fmax	0.00Hz	×
F03.15	End segment time of acceleration of S curve	0.0 ~ 6000.0s	0.0s	×

Param.	Parameter Name	Setting Range	Default	Attr
F03.16	Initial segment time of deceleration of S curve	0.0 ~ 6000.0s	0.0s	×
F03.17	End segment time of deceleration of S curve	0.0 ~ 6000.0s	0.0s	×
Group F04 Digital Input				
F04.00	Function of terminal DI1	00: No function	1	×
F04.01	Function of terminal DI2	01: Running forward (FWD)	2	×
F04.02	Function of terminal DI3	02: Running reverse (REV)	7	×
F04.03	Function of terminal DI4	03: Three-wire control	13	×
F04.04	Function of terminal DI5	04: JOG forward	0	×
F04.05	Function of terminal DI6	05: JOG reverse	0	×
F04.06	Function of terminal DI7	06: Coast to stop	0	×
F04.07	Function of terminal AI1	07: Fault reset (RESET)	0	×
F04.08	Function of terminal AI2	08: Running suspended	0	×
		09: External fault input		
		10: Terminal UP		
		11: Terminal DOWN		
		12: UP/DOWN (including ^/√key) adjustment clear		
		13: Multi-step frequency terminal 1		
		14: Multi-step frequency terminal 2		
		15: Multi-step frequency terminal 3		
		16: Multi-step frequency terminal 4		
		17: Accel/Decel time determinant 1		
		18: Accel/Decel time determinant 2		
		19: Accel/Decel disabled(ramp stop not inclusive)		
		20: Switch to auxiliary speedsetting		
		21: PLC status reset		
		22: Simple PLC paused		
		23: Simple PLC paused		
		24: PID adjustment direction		
F04.09	Function of terminal AI3	25: PID integration paused	0	×
		26: PID parameter switch		
		27: Swing frequency pause(output the current frequency)		
		28: Swing frequency reset(output the central frequency)		
		29: Run command switched to keypad control		
		30: Run command switched to terminal control		
		31: Run command switched to communication control		
		32: Count input		
		33: Count clear		
		34: Length count		
		35: Length clear		
		36: DC brake input command at Stop		
		37: Speed/torque control switch		
		38: No reverse		

Param.	Parameter Name	Setting Range	Default	Attr
		39: No forward 40: zero-serve 41: Enable spindle orientation 42: Orientation position selection 1 43: Orientation position selection 2 44: Simple carry origin signal input 45: FWD carry 46: REV carry 47: Carry amount selection terminal 1 48: Carry amount selection terminal 2 49: Carry amount selection terminal 3 70: Position given X7 direction input 71: Position Pulse Zero Clearing 72: Forward position offset enable 73: Reverse position offset enable 74: Pulse proportion selection of Ho output encoder 75: Current overrun switching 76: Carry enable		
F04.10	Filtering time of digital input terminal	0.000 ~ 1.000s	0.010s	△
F04.11	Delay time before terminal DI1 is valid	0.0 ~ 300.0s	0.0s	△
F04.12	Delay time before terminal DI2 is valid	0.0 ~ 300.0s	0.0s	△
F04.13	Terminal DI1 ~ DI5 positive/negative logic	DI5, DI4, DI3, DI2, DI1 0: Positive logic(Terminals are on at 0V/off at 24V) 1: Negative Logic (Terminals are off at 0V/on at 24V)	00000	×
F04.14	Terminal DI6 ~ AI3 positive/negative logic	AI3, AI2, AI1, DI7, DI6 0: Positive logic 1: Negative Logic	00000	×
F04.15	FWD/REV terminal control mode	0: Two-wire mode 1 1: Two-wire mode 2 2: Three-wire mode 1 3: Three-wire mode 2	0	×
F04.16	Terminal UP/DOWN frequency adjustment control	Unit's place: action when stop 0: Clear 1: Holding Ten's place: action on power loss 0: Clear 1: Holding Hundreds place: integral function 0: No integral function 1: Integral function enabled Thousand's place: Select if it can be reduced to negative frequency 0: Disable 1: Enable	00001	×

Param.	Parameter Name	Setting Range	Default	Attr
		Ten thousand's place: Jog action to clear UP/DOWN 0: Not Clear 1: Clear		
F04.17	Terminal UP/DOWN frequency change step size	0.00 ~ 50.00Hz 0.00:Disabled	1.00Hz/ 200ms	△
F04.18	Terminal action selection when power on	0: Level effective 1: Edge trigger +Level effective(When power on) 2: Edge trigger +Level effective(Every start)	0	×
F04.19	Delay time before terminal DI1 is invalid	0.0 ~ 300.0s	0.0s	△
F04.20	Delay time before terminal DI2 is invalid	0.0 ~ 300.0s	0.0s	△
Group F05 Digital Output				
F05.00	Y1 output function	00: No output	1	×
F05.01	Y2 output function	01: Drive is running	3	×
F05.02	Relay 1 output function	02: Fault output	2	×
F05.03	Relay 2 output function	03: Frequency-level detection FDT1 output 04: Frequency-level detection FDT2 output 05: Drive in 0Hz running 1(no output at stop) 06: Drive in 0Hz running 2(output at stop) 07: Upper limit frequency attained 08: Lower limit frequency attained 09: Frequency attained 10: Inverter is ready to work 11: Drive (motor) overloaded alarm 12: Inverter overheat warning 13: Current running time attained 14: Accumulative power-on time attained 15: Consecutive running time attained 16: PLC cycle completed 17: Set count value attained 18: Designated count value attained 19: Length attained 20: Under load alarm 21: Brake output 22: DI1 23: DI2 24: When reach the range of set frequency(FDT1) 25: Spindle orientation completion (FR510A only) 26: PID feedback loss 27: operation status (inching without output)	11	×

Param.	Parameter Name	Setting Range	Default	Attr
		28: communication setting (address 2007h) 30~39: Special machine output function 40: The current exceeds the limit		
F05.04	Y1 output delay time	0.0 ~ 6000.0s	0.0s	△
F05.05	Y2 output delay time	0.0 ~ 6000.0s	0.0s	△
F05.06	R1 output delay time	0.0 ~ 6000.0s	0.0s	△
F05.07	R2 output delay time	0.0 ~ 6000.0s	0.0s	△
F05.08	Enabled state of digital output	Unit's place: Y1	00000	×
		0: Positive logic		
		1: Negative logic		
		Ten's place: Y2 (same as unit's place)		
		Hundreds place: Relay 1 output (same as unit's place)		
		Thousands place: Relay 2 output (same as unit's place)		
F05.09	Detection width of frequency attained	0.00 ~ 20.00Hz	5.00Hz	×
F05.10	FDT1 upper bound	0.00 ~ Fmax	30.00Hz	×
F05.11	FDT1 lower bound	0.00 ~ Fmax	30.00Hz	×
F05.12	FDT2 upper bound	0.00 ~ Fmax	30.00Hz	×
F05.13	FDT2 lower bound	0.00 ~ Fmax	30.00Hz	×
F05.14	Consecutive running time	0.0 ~ 6000.0Min 0.0: Disabled	0.0Min	×
F05.15	Accumulative power-on time setting	0 ~ 65535h 0: Disabled	0h	×
F05.16	Accumulative running time setting	0 ~ 65535h 0: Disabled	0h	×
F05.17	Brake control selection	0: Disabled	0	×
		1: Enabled		
F05.18	Brake opened frequency	Closed frequency ~30.00Hz	2.50Hz	×
F05.19	Brake opened current	0.0~200.0%	0.0%	△
F05.20	Brake open waiting time	0.00~10.00s	0.00s	×
F05.21	Brake open operating time	0.00~10.00s	0.50s	×
F05.22	Brake closed frequency	0.00Hz~opened frequency	2.00Hz	×
F05.23	Brake close waiting time	0.00~10.00s	0.00s	×
F05.24	Brake close operating time	0.00~10.00s	0.50s	×
F05.25	Current overrun 1	0.1 ~ 1500.0A	0.0A	△
F05.26	Current overrun 2	0.1 ~ 1500.0A	0.0A	△
F05.27	Relay 3 output function	Same as F05.00	0	×
F05.28	R3 output delay time	0.0 ~ 6000.0s	0.0s	△
Group F06 Analog and Pulse Input				
F06.00	Minimum input of curve A1	0.0% ~ input of inflection point 1 of curve A1	1.0%	△

Param.	Parameter Name	Setting Range	Default	Attr
F06.01	Set value corresponding to minimum input of curve AI1	-100.0 ~ 100.0%	0.0%	△
F06.02	Input of inflection point 1 of curve AI1	Minimum input of curve AI1 ~ Input of inflection point 2 of curve AI1	100.0%	△
F06.03	Set value corresponding to input of inflection point 1 of curve AI1	-100.0 ~ 100.0%	100.0%	△
F06.04	Input of inflection point 2 of curve AI1	Input of inflection point 1 of curve AI1 ~ Maximum input of curve AI1	100.0%	△
F06.05	Set value corresponding to input of inflection point 2 of curve AI1	-100.0 ~ 100.0%	100.0%	△
F06.06	Maximum input of curve AI1	Input of inflection point 2 of curve AI1 ~ 100.0%	100.0%	△
F06.07	Set value corresponding to maximum input of curve AI1	-100.0 ~ 100.0%	100.0%	△
F06.08	Minimum input of curve AI2	0.0% ~ input of inflection point1 of curve AI2	1.0%	△
F06.09	Set value corresponding to minimum input of curve AI2	-100.0 ~ 100.0%	0.0%	△
F06.10	Input of inflection point 1 of curve AI2	Minimum input of curve AI1 ~ Input of inflection point 2 of curve AI2	100.0%	△
F06.11	Set value corresponding to input of inflection point 1 of curve AI2	-100.0 ~ 100.0%	100.0%	△
F06.12	Input of inflection point 2 of curve AI2	Input of inflection point 1 of curve AI2 ~ Maximum input of curve AI2	100.0%	△
F06.13	Set value corresponding to input of inflection point 2 of curve AI2	-100.0 ~ 100.0%	100.0%	△
F06.14	Maximum input of curve AI2	Input of inflection point A of curve AI2 ~ 100.0%	100.0%	△
F06.15	Set value corresponding to maximum input of curve AI2	-100.0 ~ 100.0%	100.0%	△
F06.16	Minimum input of curve AI3	0.0% ~ input of inflection point1 of curve AI3	0.0%	△
F06.17	Set value corresponding to minimum input of curve AI3	-100.0 ~ 100.0%	-100.0%	△
F06.18	Input of inflection point 1 of curve AI3	Minimum input of curve AI1 ~ Input of inflection point 2 of curve AI3	25.0%	△

Param.	Parameter Name	Setting Range	Default	Attr
F06.19	Set value corresponding to input of inflection point 1 of curve AI3	-100.0 ~ 100.0%	-50.0%	△
F06.20	Input of inflection point 2 of curve AI3	Input of inflection point 1 of curve AI3 ~ Maximum input of curve AI3	75.0%	△
F06.21	Set value corresponding to input of inflection point 2 of curve AI3	-100.0 ~ 100.0%	25.0%	△
F06.22	Maximum input of curve AI3	Input of inflection point A of curve AI3 ~ 100.0%	100.0%	△
F06.23	Set value corresponding to maximum input of curve AI3	-100.0 ~ 100.0%	100.0%	△
F06.24	Minimum input of curve keypad potentiometer	0.0 ~ Maximum input of curve keypad potentiometer	0.5%	△
F06.25	Set value corresponding to minimum input of curve keypad potentiometer	-100.0 ~ 100.0%	0.0%	△
F06.26	Maximum input of curve keypad potentiometer	Minimum input of curve keypad potentiometer ~ 100.0	99.9%	△
F06.27	Set value corresponding to maximum input of curve keypad potentiometer	-100.0 ~ 100.0%	100.0%	△
F06.28	AI1 terminal filtering time	0.000 ~ 10.000s	0.100s	△
F06.29	AI2 terminal filtering time	0.000 ~ 10.000s	0.100s	△
F06.30	AI3 terminal filtering time	0.000 ~ 10.000s	0.100s	△
F06.31	Keypad potentiometer filtering time	0.000 ~ 10.000s	0.100s	△
F06.32	Minimum input of curve HI	0.00 kHz ~ Maximum input of curve HI	0.00kHz	△
F06.33	Set value corresponding to minimum input of curve HI	-100.0 ~ 100.0%	0.0%	△
F06.34	Maximum input of curve HI	Minimum input of curve HI ~ 100.00kHz	50.00kHz	△
F06.35	Set value corresponding to maximum input of curve HI	-100.0 ~ 100.0%	100.0%	△
F06.36	HI terminal filtering time	0.000 ~ 10.000s	0.100s	△
Group F07 Analog and Pulse Output				
F07.00	AO1 output function	00: No output	1	×
F07.01	AO2 output function	01: Output frequency 02: Command frequency	2	×
F07.02	Y2/HO output function (when used as HO)	03: Output current 04: Output voltage 05: Output power 06: Bus voltage 07: +10V 08: keypad potentiometer 09:AI1 10:AI2	3	×

Param.	Parameter Name	Setting Range	Default	Attr
		11:AI3 12:HI 13: Output torque 14: Ao communication given 1 15: Ao communication given 2 16: Encoder input 17~99:retain		
F07.03	AO1 offset	-100.0 ~ 100.0%	0.0%	△
F07.04	AO1 gain	-2.000 ~ 2.000	1.000	△
F07.05	AO1 filtering time	0.000 ~ 10.000s	0.000s	△
F07.06	AO2 offset	-100.0 ~ 100.0%	0.00%	△
F07.07	AO2 gain	-2.000 ~ 2.000	1.000	△
F07.08	AO2 filtering time	0.000 ~ 10.000s	0.000s	△
F07.09	HO maximum output pulse frequency	0.01 ~ 100.00kHz	50.00kHz	△
F07.10	HO output filtering time	0.000 ~ 10.000s	0.010s	△
F07.11	Ho output encoder pulse proportion 1	0.00 ~ 10.00	1.00	△
F07.12	Ho output encoder pulse proportion 2	0.00 ~ 10.00	1.00	△
Group F08 Parameters of Motor 1				
F08.00	Motor 1 type selection	0: Three phase asynchronous motors 1: PMSM (FR510A only) 2: Single phase asynchronous motors (Remove capacity) 3: Single phase asynchronous motors (No need to remove capacity)	0	×
F08.01	Power rating of motor 1	0.1 ~ 1000.0kW	Model defined	×
F08.02	Rated voltage of motor 1	60 ~ 660V	Model defined	×
F08.03	Rated current of motor 1	0.1 ~ 1500.0A	Model defined	×
F08.04	Rated frequency of motor 1	20.00 ~ Fmax	Model defined	×
F08.05	Rated speed of motor 1	1 ~ 30000	Model defined	×
F08.07	Motor 1 rated power factor	0.50~0.99	Model defined	×
F08.08	Stator resistance R1 of async motor 1	0.001 ~ 65.535Ω	Model defined	×
F08.09	Rotor resistance R2 of async motor 1	0.001 ~ 65.535Ω	Model defined	×
F08.10	Leakage inductance L1 of async motor 1	0.01 ~ 655.35mH	Model defined	×
F08.11	Mutual inductance L2 of asynchronous motor 1	0.1 ~ 6553.5mH	Model defined	×

Param.	Parameter Name	Setting Range	Default	Attr
F08.12	No-load current of async motor 1	0.1 ~ 1500.0A	Model defined	×
F08.13	Field weakening coeff 1 of async motor 1	0.0 ~ 100.0	87%	×
F08.14	Field weakening coeff 2 of async motor 1	0.0 ~ 100.0	75%	×
F08.15	Field weakening coeff 3 of async motor 1	0.0 ~ 100.0	70%	×
F08.16	PMSM stator resistance	0.001 ~ 65.535Ω	Model defined	×
F08.17	PMSM d-axis inductance	0.01 ~ 655.35mH	Model defined	×
F08.18	PMSM d-axis inductance	0.01 ~ 655.35mH	Model defined	×
F08.19	PMSM back EMF	0 ~ 65535V	Model defined	×
F08.20	Installation angle of encoder	0.0 ~ 359.9°	0.0°	×
F08.21	Pole number of motor	0 ~ 1000	4	×
F08.22	Find encoder origin at beginning	0: Not find 1: Find	1	×
F08.23	Encoder line number	0 ~ 10000	1024	×
F08.24	Encoder type	0: ABZ encoder 1: UVW encoder 2: Rotary encoder 3: ECN1313 4: Sine-cosine encoder	0	×
F08.25	AB Phase Sequence of ABZ Incremental Encoder	0: Positive 1: Negative	0	×
F08.26	Speed feedback PG disconnection detection	0.0: Invalid 0.1 ~ 10.0s	0.0s	×
F08.27	Speed Ratio of Motor to Encoder	0.001 ~ 60.000	1.000	×
F08.28	Pole pairs of rotary encoder	1 ~ 100	1	×
F08.29	Reserved for PG card parameters			
F08.30	Autotuning of motor 1	0: No autotuning 1: Static autotuning of motor 2: Rotary autotuning of motor	0	×
Group F09 V/f Control Parameters of Motor 1				
F09.00	V/f curve setting	00: Linear V/F	0	×
		01: Multi-stage V/F		
		02: 1.2nd power V/F		
		03: 1.4nd power V/F		
		04: 1.6nd power V/F		
		05: 1.8nd power V/F		
		06: 2.0nd power V/F		
		07: V/F complete separation		
		08: V/F half separation		

Param.	Parameter Name	Setting Range	Default	Attr
		09: 1.2 power inverse curve V/F 10: 1.4 power inverse curve V/F 11: 1.6 power inverse curve V/F 12: 1.8 power inverse curve V/F 13: 2.0 power inverse curve V/F		
F09.01	Torque boost	0.0%~30.0% 0.0% (fixed torque boost)	0.0%	△
F09.02	Cut-off frequency of torque boost	0.00 ~ Fmax	50.00Hz	△
F09.03	Multi-point V/F frequency 1(F1)	0.00 ~ F09.05	0.00Hz	△
F09.04	Multi-point V/F voltage 1 (V1)	0.0 ~ 100.0	5.0%	△
F09.05	Multi-point V/F frequency 2(F2)	F09.03 ~ F09.05	5.00Hz	△
F09.06	Multi-point V/F voltage 2 (V2)	0.0 ~ 100.0	14.0%	△
F09.07	Multi-point V/F frequency 3(F3)	F09.05 ~ F09.09	25.00Hz	△
F09.08	Multi-point V/F voltage 3 (V3)	0.0 ~ 100.0	50.0%	△
F09.09	Multi-point V/F frequency 4(F4)	F09.07 ~ rated motor frequency	50.00Hz	△
F09.10	Multi-point V/F voltage 4 (V4)	0.0 ~ 100.0 Ue=100.0%	100.0%	△
F09.11	V/F slip compensation gain	0.0 ~ 300.0%	80.0%	△
F09.12	Stator voltage drop compensation gain	0.0 ~ 200.0%	100.0%	△
F09.13	Excitation boost gain	0.0 ~ 200.0%	100.0%	△
F09.14	Oscillation Suppression	0.0 ~ 300.0%	100.0%	△
F09.15	Voltage source for V/F separation	0: Digital setting (F09.16) 1: keypad potentiometer 2: AI1 3: Multi-reference 4: Pulse setting (DI7/HI) 5: PID 6: AI2 7: AI3	0	×
F09.16	Voltage digital setting for V/F separation	0 V to rated motor voltage	0.0%	△
F09.17	Voltage rise time of V/F separation	0.0 ~ 6000.0s It indicates the time for the voltage rising from 0 V to rated Motor voltage.	0.1s	△
F09.18	Set the IQ filter time below 0.5Hz in VVF mode	F09.19 ~ 3000ms	500ms	×
F09.19	Set the IQ filter time above 2Hz in VVF mode	1ms ~ F09.18	100ms	×
F09.20	Torque revision when run forward	0.0 ~ 5.0%	0.0%	△

Param.	Parameter Name	Setting Range	Default	Attr
F09.21	Torque revision when run reverse	0.0 ~ 5.0%	1.0%	△
F09.22	PMSM acceleration current compensation setting(FR510A only)	0.0 ~ 200.0%	0.0%	△
F09.23	PMSM compensation time decreased after acceleration (FR510A only)	0.0 ~ 100.0s	2.0s	△
F09.24	PMSM ID current value will be maintained after accelerating. (FR510A only)	0.0 ~ 200.0%	0.0%	△
Group F10 Vector Control Parameters of Motor 1				
F10.00	Speed/torque control	0: speed control 1: torque control	0	×
F10.01	ASR low-speed proportional gain Kp1	0.0 ~ 100.0	30.0	△
F10.02	ASR low-speed integration time Ti1	0.001 ~ 30.000s	0.100s	△
F10.03	ASR switching frequency 1	0.00 ~ F10.06	5.00Hz	△
F10.04	ASR high-speed proportional gain Kp2	1 ~ 100.0	10.0	△
F10.05	ASR high-speed integration time Ti2	0.001 ~ 30.000s	0.500s	△
F10.06	ASR switching frequency 2	F10.03 ~ Fmax	10.00Hz	△
F10.07	ASR input filtering time	0.0 ~ 500.0ms	3.0ms	△
F10.08	ASR output filtering time	0.0 ~ 500.0ms	0.0ms	△
F10.09	Vector control slip gain	50 ~ 200%	100%	△
F10.10	Digital setting of torque upper limit in speed control mode	80.0 ~ 200.0%	165.0%	×
F10.11	Excitation adjustment proportional gain Kp1	0.00 ~ 10.00	0.50	△
F10.12	Excitation adjustment integral gain Ki1	0.000~10.0000 0.0: No points	0.800	△
F10.13	Torque adjustment proportional gain Kp2	0.00 ~ 10.00	0.50	△
F10.14	Torque adjustment integral gain Ki2	0.000~10.0000 0.0: No points	0.800	△
F10.15	Excitation gain coefficient	50.0~200%	100%	△
F10.16	Torque setting source under torque control	0: Set by F10.17	0	×
		1: Keypad potentiometer		
		2: AI1		
		3: AI2		
		4: AI3		

Param.	Parameter Name	Setting Range	Default	Attr
		5: Pulse setting (DI7/HI)		
		6: Communication setting		
F10.17	Digital setting of torque	-200.0 ~ 200.0%	50.0%	△
F10.18	Forward speed limited value under torque control	0.00 ~ Fmax	50.00Hz	△
F10.19	Reverse speed limited value under torque control	0.00 ~ Fmax	50.00Hz	△
F10.20	Set torque accel time	0.0 ~ 6000.0s	0.0s	△
F10.21	Set torque decel time	0.0 ~ 6000.0s	0.0s	△
F10.22	Static friction torque compensation	0.0 ~ 100.0%	5.00%	△
F10.23	Static friction frequency range	0.00 ~ 50.00Hz	5.00Hz	△
F10.24	Static Frequency of Open-Loop Torque	1.00 ~ 10.00Hz	1.00Hz	△
F10.25	SVC optimization method	0: Optimization method 1 1: Optimization method 2 2: Optimization method 3	1	×
F10.26	Max Frequency source under torque control	0: Set by F10.18 & F10.19	0	×
		1: Keypad potentiometer		
		2: AI1		
		3: AI2		
		4: AI3		
		5: Pulse setting (DI7/HI)		
F10.27	PMSM Start Excitation Current	0.0 ~ 150.0%	30.0%	×
F10.28	PMSM Flux weakening control	0: Invalid 1: Valid	1	×
F10.29	PMSM Flux weakening Voltage	70.0 ~ 100.0%	95.0%	△
F10.30	PMSM Flux weakening gain(Kp)	0.0 ~ 500.0%	50.0%	△
F10.31	PMSM Flux weakening integral(Ti)	0.00 ~ 60.00s	0.5s	△
F10.32	PMSM Flux weakening limit	0.0 ~ 200.0%	100.0%	△
F10.33	PMSM excitation current frequency high point	F10.34 ~ 590.00Hz	15.00Hz	△
F10.34	PMSM excitation current frequency low point	0.0 ~ F10.33	10.00Hz	△
F10.35	PMSM excitation current conversion delay	0.0 ~ 10.0s	1.0s	△
F10.36	PMSM speed estimation Kp	0.00 ~ 10.00	2.00	△
F10.37	PMSM speed estimation Ti	0.1 ~ 1000.0ms	20.0ms	△
F10.38	Sliding mode filtering ratio of synchronous motor	0.0001 ~ 2.0000	0.1057	△

Param.	Parameter Name	Setting Range	Default	Attr
Group F11 Protection Parameters				
F11.00	Current limit control	0: Current limit disabled 1: Current limit mode 1 2: Current limit mode 2	2	×
F11.01	Current limit	100.0 ~ 200.0%	150.0%	×
F11.02	Frequency decreasing time(limit current in constant speed operation)	0.0 ~ 6000.0s	5.0s	△
F11.03	Current limit mode 2 proportion gain	0.1 ~ 100.0%	3.0%	△
F11.04	Current limit mode 2 integral time	0.00 ~ 10.00s	1.00s	△
F11.05	Overvoltage Stall Control	0: Overvoltage stall disabled 1: Overvoltage stall mode 1 2: Overvoltage stall mode 2	2	×
F11.06	Overvoltage stall voltage	600 ~ 800V(380V Inverter) 320 ~ 400V(220V Inverter)	730V 370V	×
F11.07	Overvoltage Stall Mode 2 Proportion Gain	0.0 ~ 300.0%	50.0%	△
F11.08	Overvoltage stall mode 2 frequency limit	0.00 ~ 50.00Hz	5.00Hz	×
F11.09	Retain		0	
F11.10	Protection action 1	Unit's place: Bus undervoltage 0: Fault reported and coast to stop 1: Stop according to the stop mode 2: Fault reported but continue to run 3: Fault protection disabled Ten's place:Power input phase Loss (Err09) (Same as unit's place) Hundred's place:Power output phase loss(Err10) (Same as unit's place) Thousand's place:Motor overload (Err11)(Same as unit's place) Ten thousand's place:Inverter overload(Err12) (Same as unit's place)	03330	×
F11.11	Protection action 2	External equipment fault (Err13) 0: Fault reported and coast to stop 1: Stop according to the stop mode 2: Fault reported but continue to run Ten's place: EEPROM read/write fault (Err15) (Same as unit's place) Hundred's place: Communication overtime error (Err18) (Same as unit's place)	00000	×

Param.	Parameter Name	Setting Range	Default	Attr
		Thousand's place: PID feedback loss (Err19) (Same as unit's place)		
		Ten thousand's place: Continuous running time reached (Err20) (Same as unit's place)		
F11.12	Protection action 3	Unit's place: Module temperature detection disconnection (Err24) 0: Fault reported and coast to stop 1: Stop according to the stop mode 2: Fault reported but continue to run	00030	×
		Ten's place: Load becoming 0 (Err25) (Same as unit's place)		
F11.13	Protection action 4	Retain	0000	×
F11.14	Frequency selection for continuing to run upon fault	0: Current running frequency 1: Set frequency 2: Frequency upper limit 3: Frequency lower limit 4: Backup frequency upon abnormality	1	×
F11.15	Backup frequency upon abnormality	0.00 ~ Fmax	0.00Hz	×
F11.16	Retain			
F11.17	Motor overload protection time	30.0 ~ 300.0s	60.0s	×
F11.18	Overload alarm	Unit's place: detection option: 0: Always detect 1: Detect at constant speed only Ten's place: compared object 0: Rated current of motor 1: Rated current of drive 2: Relative motor rated power 3: Relative frequency converter rated power Hundred's place: Fault reported 0: No fault reported 1: Fault reported 2: Display warning Thousand's place: whether to decelerate or not when overload alarm 0: No deceleration 1: Deceleration 2: PI adjustment (PI parameters are F13.08 and F13.09) Ten thousand's place: given mode for overload threshold 0: F11.19 set 1: F11.19*VP 2: F11.19*AI1 3: F11.19*AI2 4: F11.19*AI3	00010	×

Param.	Parameter Name	Setting Range	Default	Attr
F11.19	Overload alarm threshold	20.0 ~ 200.0%	130.0%	×
F11.20	Overload alarm activated time that exceeding threshold	0.1 ~ 60.0s	5.0s	×
F11.21	Inverter overheat warning threshold	50 ~ overheat Temperature	Model defined	×
F11.22	Detection level of load loss	5.0 ~ 100.0%	20.0%	×
F11.23	Detection time of load loss	0.1 ~ 60.0s	5.0s	×
F11.24	Action selection at instantaneous power failure	0: Disabled	0	×
		1: Deceleration		
		2: Bus voltage constant control		
F11.25	Decel time at instantaneous power failure	0.0 ~ 6000.0s	5.0s	△
F11.26	Rapid current limit	0: Disabled	2	×
		1: Rapid current limiting mode 1		
		2: Rapid current limiting mode 2		
F11.27	Times of automatic trip(fault) reset	0 ~ 20	0	×
F11.28	Interval of automatic trip(fault) reset	0.1 ~ 100.0s	1.0s	×
F11.29	DO action during fault auto reset	0: Not act	0	×
		1: Act		
F11.30	Instantaneous power off bus voltage	60.0% ~ Recovery voltage	80.0%	△
F11.31	Instantaneous power off recovery voltage	Power off voltage ~ 100.0%	85.0%	△
F11.32	Instantaneous power off voltage detection time	0.01 ~ 10.00s	0.10s	△
F11.33	Instantaneous power off Kp	0.1 ~ 100.0%	40.0%	△
F11.34	Instantaneous power off integration time Ti	0.00 ~ 10.00s (0.00: Integration invalid)	0.10s	△
F11.35	Motor temperature sensor type	0:None 1:PT100 2:PT1000 3:KTY84	0	×
F11.36	Zero drift value of motor temperature sensor	-100 ~ 100℃	0	△
F11.37	Reserved			
F11.38	Motor temperature warning action threshold	0 ~ 200℃	90℃	△
F11.39	Motor temperature protection action threshold	0 ~ 200℃	110℃	△

Param.	Parameter Name	Setting Range	Default	Attr
F11.40	Action selection of Excessive Speed and Excessive Speed Deviation	Unit's place:Overspeed Action Selection 0:Report error and coast to stop 1:Warning and ramp to stop 2:Alarm and continue run with failure frequency 3:No protection Ten's place:Selection of Excessive Speed Deviation 0:Report error and coast to stop 1:Warning and ramp to stop 2:Alarm and continue run with failure frequency 3:No protection	00	×
F11.41	Overspeed detection value(FR510A only)	0.0 ~ 150.0%	120.0%	×
F11.42	Overspeed detection time(FR510A only)	0.0 ~ 60.0s	1.0s	×
F11.43	Detection value of excessive velocity deviation(FR510A only)	0.0 ~ 50.0%	20.0%	×
F11.44	Detection time of excessive velocity deviation(FR510A only)	0.0 ~ 60.0s	5.0s	×
Group F12: Multi-Reference and Simple PLC Function				
F12.00	Reference 0	-100.0 ~ 100.0%	0.0%	△
F12.01	Reference 1	-100.0 ~ 100.0%	0.0%	△
F12.02	Reference 2	-100.0 ~ 100.0%	0.0%	△
F12.03	Reference 3	-100.0 ~ 100.0%	0.0%	△
F12.04	Reference 4	-100.0 ~ 100.0%	0.0%	△
F12.05	Reference 5	-100.0 ~ 100.0%	0.0%	△
F12.06	Reference 6	-100.0 ~ 100.0%	0.0%	△
F12.07	Reference 7	-100.0 ~ 100.0%	0.0%	△
F12.08	Reference 8	-100.0 ~ 100.0%	0.0%	△
F12.09	Reference 9	-100.0 ~ 100.0%	0.0%	△
F12.10	Reference 10	-100.0 ~ 100.0%	0.0%	△
F12.11	Reference 11	-100.0 ~ 100.0%	0.0%	△
F12.12	Reference 12	-100.0 ~ 100.0%	0.0%	△
F12.13	Reference 13	-100.0 ~ 100.0%	0.0%	△
F12.14	Reference 14	-100.0 ~ 100.0%	0.0%	△
F12.15	Reference 15	-100.0 ~ 100.0%	0.0%	△
F12.16	Reference 0 source	0: Digital setting (F12.00) 1:keypad potentiometer	0	×

Param.	Parameter Name	Setting Range	Default	Attr
		2: AI1		
		3: Process PID output		
		4: X7/HI pulse input		
		5: AI2		
		6: AI3		
F12.17	Running mode of simple PLC	Unit's place: PLC running mode 0: Stop after a single cycle 1: Continue to run with the last frequency after a single cycle 2: Repeat cycles Ten's place: started mode 0: Continue to run from the step of stop (or fault) 1: Run from the first step "multi-step frequency 0" 2: Run from the eighth step "multi-step frequency 8" 3: Run from the fifteenth step "multi-step frequency 15" Hundreds place: power loss memory 0: Memory disabled on power loss 1: Memory enabled on power loss Thousands place: unit of simple PLC running time 0: Second (s) 1: Minute (min)	00000	×
F12.18	Running time of step 0	0.0 ~ 6000.0s(h)	0.0s(h)	△
F12.19	Running time of step 1	0.0 ~ 6000.0s(h)	0.0s(h)	△
F12.20	Running time of step 2	0.0 ~ 6000.0s(h)	0.0s(h)	△
F12.21	Running time of step 3	0.0 ~ 6000.0s(h)	0.0s(h)	△
F12.22	Running time of step 4	0.0 ~ 6000.0s(h)	0.0s(h)	△
F12.23	Running time of step 5	0.0 ~ 6000.0s(h)	0.0s(h)	△
F12.24	Running time of step 6	0.0 ~ 6000.0s(h)	0.0s(h)	△
F12.25	Running time of step 7	0.0 ~ 6000.0s(h)	0.0s(h)	△
F12.26	Running time of step 8	0.0 ~ 6000.0s(h)	0.0s(h)	△
F12.27	Running time of step 9	0.0 ~ 6000.0s(h)	0.0s(h)	△
F12.28	Running time of step 10	0.0 ~ 6000.0s(h)	0.0s(h)	△
F12.29	Running time of step 11	0.0 ~ 6000.0s(h)	0.0s(h)	△
F12.30	Running time of step 12	0.0 ~ 6000.0s(h)	0.0s(h)	△
F12.31	Running time of step 13	0.0 ~ 6000.0s(h)	0.0s(h)	△
F12.32	Running time of step 14	0.0 ~ 6000.0s(h)	0.0s(h)	△
F12.33	Running time of step 15	0.0 ~ 6000.0s(h)	0.0s(h)	△

Param.	Parameter Name	Setting Range	Default	Attr
F12.34	Acceleration/deceleration time of simple PLC reference 0	0 ~ 3	0	△
F12.35	Acceleration/deceleration time of simple PLC reference 1	0 ~ 3	0	△
F12.36	Acceleration/deceleration time of simple PLC reference 2	0 ~ 3	0	△
F12.37	Acceleration/deceleration time of simple PLC reference 3	0 ~ 3	0	△
F12.38	Acceleration/deceleration time of simple PLC reference 4	0 ~ 3	0	△
F12.39	Acceleration/deceleration time of simple PLC reference 5	0 ~ 3	0	△
F12.40	Acceleration/deceleration time of simple PLC reference 6	0 ~ 3	0	△
F12.41	Acceleration/deceleration time of simple PLC reference 7	0 ~ 3	0	△
F12.42	Acceleration/deceleration time of simple PLC reference 8	0 ~ 3	0	△
F12.43	Acceleration/deceleration time of simple PLC reference 9	0 ~ 3	0	△
F12.44	Acceleration/deceleration time of simple PLC reference 10	0 ~ 3	0	△
F12.45	Acceleration/deceleration time of simple PLC reference 11	0 ~ 3	0	△
F12.46	Acceleration/deceleration time of simple PLC reference 12	0 ~ 3	0	△
F12.47	Acceleration/deceleration time of simple PLC reference 13	0 ~ 3	0	△
F12.48	Acceleration/deceleration time of simple PLC reference 14	0 ~ 3	0	△
F12.49	Acceleration/deceleration time of simple PLC reference 15	0 ~ 3	0	△

Param.	Parameter Name	Setting Range	Default	Attr
F12.50	UP/DOWN function selection of Multi-reference	Unit's place: Action selection when power off 0:Zero clearing when power off 1:Hold when power off Ten's place: select if it can be reduced to negative 0:Disable 1:Enable	00	×
F12.51	UP/DOWN speed of Multi-reference	0.0 ~ 100.0% (0.0%Invalid)	0.0%	△
Group F13 Process PID				
F13.00	PID setting	0: F13.01 digital setting 1:keypad potentiometer 2: AI1 3: Communication 4: Multi-Reference 5: DI7/HI pulse input 6: AI2 7: AI3	0	×
F13.01	PID digital setting	0.0 ~ 100.0%	50.0%	△
F13.02	PID feedback	0: AI1 1: AI2 2: Communication 3: AI1+AI2 4: AI1-AI2 5: Max{AI1, AI2} 6: Min{AI1, AI2} 7: DI7/HI pulse input 8: AI3	0	×
F13.03	PID setting feedback range	0.0 ~ 6000.0	1000.0	△
F13.04	PID action direction	0: Forward action 1: Reverse action	0	×
F13.05	Filtering time of PID setting	0.000 ~ 10.000s	0.000s	△
F13.06	Filtering time of PID feedback	0.000 ~ 10.000s	0.000s	△
F13.07	Filtering time of PID output	0.000 ~ 10.000s	0.000s	△
F13.08	Proportional gain Kp1	0.0 ~ 1000.0	1.0	△
F13.09	Integration time Ti1	0.01 ~ 10.00s	0.10s	△
F13.10	Differential time Td1	0.000 ~ 10.000s	0.000s	△
F13.11	Proportional gain Kp2	0.0 ~ 100.0	20.0	△
F13.12	Integration time Ti2	0.01 ~ 10.00s	2.00s	△
F13.13	Differential time Td2	0.000 ~ 10.000s	0.000s	△

Param.	Parameter Name	Setting Range	Default	Attr
F13.14	PID parameter switch	0: No switch, determined by parameters Kp1, Ti1 and Td1	0	×
		1: Auto switch on the basis of input offset		
		2: Switched by terminal		
F13.15	PID parameter switchover deviation 1	0.0 ~ 100.0%	20.0%	×
F13.16	PID parameter switchover deviation 2	0.0 ~ 100.0%	80.0%	×
F13.17	PID offset limit	0.0 ~ 100.0%	0.0%	×
F13.18	PID integral property	Unit's place (Whether to stop integral operation when the output reaches the limit) 0: Continue integral operation 1: Stop integral operation	00	×
		Ten's place (Integral separated) 0: Invalid 1: Valid		
F13.19	PID differential limit	0.0 ~ 100.0%	0.5%	×
F13.20	PID initial value	0.0 ~ 100.0%	0.0%	×
F13.21	Holding time of PID initial value	0.0 ~ 6000.0s	0.0s	×
F13.22	PID output frequency upper limit	PID output frequency lower limit ~ 100.0% (100.0% corresponds to maximum frequency)	100.0%	×
F13.23	PID output frequency lower limit	-100.0% ~ PID output frequency lower limit	0.0%	×
F13.24	Low value ofPID feedback loss	0.1 ~ 100.0% 0.0%: Not judging feedback loss	0.0%	×
F13.25	Detection time for low value of PID feedback loss	0.0 ~ 30.0s	1.0s	×
F13.26	PID operation selection	Unit's place: PID operation selection when stop 0:Do not operate when stop 1:Operate when stop	00000	×
		Ten's place: output is limited by output frequency 0:No limited 1:limited		
		Hundred's place: UP/DOWN digital given of PID 0:Zero clearing when power off 1:Hold when power off		
		Thousand's place: PID feedback loss detection when stop 0:Not detect when stop 1:detect when stop		

Param.	Parameter Name	Setting Range	Default	Attr
		Then thousand's place: action for PID feedback loss 0:Report fault 1:Ramp to stop		
F13.27	UP/DWON speed of PID digital given	0.0 ~ 100.0% (0.0% Invalid)	0.0%	△
F13.28	High value ofPID feedback loss	0.1 ~ 100.0% 0.0%: Not judging feedback loss	100.0%	×
F13.29	Detection time for high value of PID feedback loss	0.0 ~ 30.0s	1.0s	×
F13.30	PID upper limit source	0:F13.22 1:F13.22*VP 2:F13.22*AI1 3:F13.22*AI2 4:F13.22*HI 5:F13.22*AI3	0	×
F13.31	PID lower limit source	0:F13.23 1:F13.23*VP 2:F13.23*AI1 3:F13.23*AI2 4:F13.23*HI 5:F13.23*AI3	0	×
Group F14: Swing Frequency, Fixed Length , Wakeup and Count				
F14.00	Swing frequency setting mode	0: Relative to the setting frequency 1: Relative to the maximum frequency	0	×
F14.01	Swing frequency amplitude	0.0 ~ 100.0%	0.0%	△
F14.02	Jump frequency amplitude	0.0 ~ 50.0%	0.0%	△
F14.03	Rising Time of Swing frequency	0.0 ~ 6000.0s	5.0s	△
F14.04	Dropping Time of Swing frequency	0.0 ~ 6000.0s	5.0s	△
F14.05	Set length	0m ~ 65535m	1000m	×
F14.06	Number of pulses per meter	0.1 ~ 6553.5	100.0	×
F14.07	Command when the length attained	Unit's place: stop when the length reaches 0: Not stop 1: Stop Ten's place: length calculation method 0: pulse by pulse 1: Reference maximum frequency 2: Refer to Ai1 channel 3: Refer to AI2 channel 4: Refer to AI3 channel	00	×
F14.08	Set count value	1 ~ 65535	1000	×
F14.09	Designated count value	1 ~ 65535	1000	×
F14.10	Wakeup frequency	Dormant frequency (F14.12) ~ Fmax	0.00Hz	△

Param.	Parameter Name	Setting Range	Default	Attr
F14.11	Wakeup delay time	0.0 ~ 6000.0s	0.0s	△
F14.12	Dormant frequency	0.00 ~ Wakeup frequency	0.00Hz	△
F14.13	Dormant delay time	0.0 ~ 6000.0s	0.0s	△
F14.14	Wake up mode selection	0: Frequency 1: Pressure	0	×
F14.15	Dormancy mode selection	0: Frequency 1: Pressure	0	×
F14.16	Voltage feedback source	Unit's place: pressure feedback 0: AI1 1: AI2 2: DI7/HI pulse input 3: AI3 Ten's place: pressure dormancy mode 0: Positive direction, dormancy on big pressure and wakeup on small pressure 1: Negative direction, dormancy on small pressure and wakeup on big pressure	0	×
F14.17	Wake up pressure	0.0% ~ 100.0%	10.0%	△
F14.18	Dormancy pressure	0.0% ~ 100.0%	50.0%	△
Group F15: Communication Parameters				
F15.00	Baud rate	0: 4800bps 1: 9600bps 2: 19200bps 3: 38400bps 4: 57600bps 5: 115200bps	1	×
F15.01	Data format	No check, data format (1-8-N-2) for RTU 1: Even parity check, data format (1-8-E-1) for RTU 2: Odd Parity check, data format (1-8-O-1) for RTU 3: No check, data format(1-8-N-1) for RTU	0	×
F15.02	Local address	1 ~ 247 0: Broadcast address	1	×
F15.03	Communication timeout	0.0 ~ 60.0s	0.0s	×
F15.04	Response time delay	0 ~ 200ms	1ms	×
F15.05	Master-slave Communication Mode	0: The inverter is the slave 1: The inverter is the master	0	×
F15.06	The Master Communication Sending Data	0: Set frequency 1: Current running frequency	0	×
F15.07	Message return when communication error	0: No return 1: Return	1	

Param.	Parameter Name	Setting Range	Default	Attr
F15.08	U group return value	0: Positive and negative	0	△
		1: Absolute value		
Group F16 Keys and Display of Keyboard Parameters				
F16.00	MF.K key setting	0: No function	1	×
		1: Jog		
		2: Forward/reverse switchover		
		3: Run command sources shifted		
F16.01	Keyboard operation display	4: Jog reverse	0001	×
		Unit's digit: Function selection of STOP/RESET key 0: stop function of STOP/RESET key is valid only in keyboard operation mode 1: Stop function of STOP/RES key is valid in any operation mode		
		Ten's digit: Speed display (U00.05) 0: According to the actual speed 1: Multiply frequency by speed coefficient(F16.11)		
		Hundred's digit: Decimal places 0: No decimal places 1: One decimal places 2: Two decimal places 3: Three decimal places		
		Thousands: U00.04 power display 0: Total power 1: Active power		
F16.02	Keys locked option	0: Not locked	0	×
		1: Full locked		
		2: Keys locked other than RUN, STOP/RST		
		3: Keys locked other than STOP/RST		
		4: Keys locked other than >>		
F16.03	LED displayed parameters setting 1 on running status	0 ~ 99(correspond U00.00 ~ U00.99)	0	△
F16.04	LED displayed parameters setting 2 on running status	0 ~ 99(correspond U00.00 ~ U00.99)	6	△
F16.05	LED displayed parameters setting 3 on running status	0 ~ 99(correspond U00.00 ~ U00.99)	3	△
F16.06	LED displayed parameters setting 4 on running status	0 ~ 99(correspond U00.00 ~ U00.99)	2	△
F16.07	LED displayed parameters setting 1 on stop status	0 ~ 99(correspond U00.00 ~ U00.99)	1	△
F16.08	LED displayed parameters setting 2 on stop status	0 ~ 99(correspond U00.00 ~ U00.99)	6	△
F16.09	LED displayed parameters setting 3 on stop status	0 ~ 99(correspond U00.00 ~ U00.99)	15	△
F16.10	LED displayed parameters setting 4 on stop status	0 ~ 99(correspond U00.00 ~ U00.99)	16	△
F16.11	Speed display coefficient	0.00~100.00	1.00	△

Param.	Parameter Name	Setting Range	Default	Attr
F16.12	Power display coefficient	0.0~300.0%	100.0%	△
F16.13	The enable difference range of U00.00 and U00.01	0.00Hz~5.00Hz	0.10Hz	△
Group F17 User-defined Display Parameters				
F17.00	User-defined Display Parameter 0	00.00 ~ 49.99	00.00	△
F17.01	User-defined Display Parameter 1	00.00 ~ 49.99	00.00	△
F17.02	User-defined Display Parameter 2	00.00 ~ 49.99	00.00	△
F17.03	User-defined Display Parameter 3	00.00 ~ 49.99	00.00	△
F17.04	User-defined Display Parameter 4	00.00 ~ 49.99	00.00	△
F17.05	User-defined Display Parameter 5	00.00 ~ 49.99	00.00	△
F17.06	User-defined Display Parameter 6	00.00 ~ 49.99	00.00	△
F17.07	User-defined Display Parameter 7	00.00 ~ 49.99	00.00	△
F17.08	User-defined Display Parameter 8	00.00 ~ 49.99	00.00	△
F17.09	User-defined Display Parameter 9	00.00 ~ 49.99	00.00	△
F17.10	User-defined Display Parameter 10	00.00 ~ 49.99	00.00	△
F17.11	User-defined Display Parameter 11	00.00 ~ 49.99	00.00	△
F17.12	User-defined Display Parameter 12	00.00 ~ 49.99	00.00	△
F17.13	User-defined Display Parameter 13	00.00 ~ 49.99	00.00	△
F17.14	User-defined Display Parameter 14	00.00 ~ 49.99	00.00	△
F17.15	User-defined Display Parameter 15	00.00 ~ 49.99	00.00	△
F17.16	User-defined Display Parameter 16	00.00 ~ 49.99	00.00	△
F17.17	User-defined Display Parameter 17	00.00 ~ 49.99	00.00	△
F17.18	User-defined Display Parameter 18	00.00 ~ 49.99	00.00	△
F17.19	User-defined Display Parameter 19	00.00 ~ 49.99	00.00	△
F17.20	User-defined Display Parameter 20	00.00 ~ 49.99	00.00	△
F17.21	User-defined Display Parameter 21	00.00 ~ 49.99	00.00	△
F17.22	User-defined Display Parameter 22	00.00 ~ 49.99	00.00	△

Param.	Parameter Name	Setting Range	Default	Attr
F17.23	User-defined Display Parameter 23	00.00 ~ 49.99	00.00	△
F17.24	User-defined Display Parameter 24	00.00 ~ 49.99	00.00	△
F17.25	User-defined Display Parameter 25	00.00 ~ 49.99	00.00	△
F17.26	User-defined Display Parameter 26	00.00 ~ 49.99	00.00	△
F17.27	User-defined Display Parameter 27	00.00 ~ 49.99	00.00	△
F17.28	User-defined Display Parameter 28	00.00 ~ 49.99	00.00	△
F17.29	User-defined Display Parameter 29	00.00 ~ 49.99	00.00	△
Group F18 Parameters of Motor 2(Refer to Group F08)				
Group F19 V/f Control Parameters of Motor 2(Refer to Group F09)				
Group F20 Vector Control Parameters of Motor 2(Refer to Group F10)				
Group F21 Position Control				
F21.00	Selection of Position Control Mode	0:Non-position control	0	x
		1:Zero Servo (Frequency Achievement Effective)		
		2:Zero Servo (Terminal Effective)		
		3:Spindle orientation		
		4:Simple carry		
F21.01	Position loop gain	0.000 ~ 40.000	1.000	△
F21.02	Zero Servo Initiation Frequency	0.00Hz ~ Fmax	1.00Hz	x
F21.03	Location completion width	0 ~ 3000	10	x
F21.04	Location completion time	0.000 ~ 40.000s	0.200s	x
F21.05	Spindle orientation position 1	0 ~ 40000	0	△
F21.06	Spindle orientation position 2	0 ~ 40000	0	△
F21.07	Spindle orientation position 3	0 ~ 40000	0	△
F21.08	Spindle orientation position 4	0 ~ 40000	0	△
F21.09	Spindle orientation	Unit's place: spindle orientation direction 0: Orient from current direction of rotation 1: Direction from positive direction 2: Orient from reverse direction	00	x
		Ten's place: positioning when parking 0: Do not locate when parking 1: Positioning when parking		
F21.10	Spindle orientation speed	0.00Hz ~ Fmax	10.00Hz	x

Param.	Parameter Name	Setting Range	Default	Attr
F21.11	Spindle orientation deceleration time	0.0 ~ 60.0s	2.0s	×
F21.12	Orientation position confirmation time	0.000 ~ 6.000s	0.010s	×
F21.13	Regression Origin Selection	Unit's place: back to origin selection 0: Invalid 1: Valid	00	×
		Ten's place: whether carry requires terminal enable signal 0: no need 1: Need		
F21.14	Regression Origin Direction	0:Forward	0	×
		1:Reverse		
F21.15	Regression Origin Frequency 1	0.00Hz ~ 590.00Hz	10.00Hz	×
F21.16	Regression Origin Frequency 2	0.00Hz ~ 60.00Hz	1.00Hz	×
F21.17	Carry amount 0 high	0 ~ 9999	0	△
F21.18	Carry amount 0 low	0 ~ 9999	0	△
F21.19	Carry amount 1 high	0 ~ 9999	0	△
F21.20	Carry amount 1 low	0 ~ 9999	0	△
F21.21	Carry amount 2 high	0 ~ 9999	0	△
F21.22	Carry amount 2 low	0 ~ 9999	0	△
F21.23	Carry amount 3 high	0 ~ 9999	0	△
F21.24	Carry amount 3 low	0 ~ 9999	0	△
F21.25	Carry amount 4 high	0 ~ 9999	0	△
F21.26	Carry amount 4 low	0 ~ 9999	0	△
F21.27	Carry amount 5 high	0 ~ 9999	0	△
F21.28	Carry amount 5 low	0 ~ 9999	0	△
F21.29	Carry amount 6 high	0 ~ 9999	0	△
F21.30	Carry amount 6 low	0 ~ 9999	0	△
F21.31	Carry amount 7 high	0 ~ 9999	0	△
F21.32	Carry amount 7 low	0 ~ 9999	0	△
F21.33	Selection of Position-Given Mode	0:X7 pulse input 1:Encoder gives A/B phase pulse, A phase ahead B phase 90 reads forward 2:Encoder gives A/B phase pulse, B phase ahead A phase 90 reads forward	0	×
F21.34	Electronic Gear Ratio Molecule	1 ~ 9999	1000	×

Param.	Parameter Name	Setting Range	Default	Attr
F21.35	Electronic gear denominator	1 ~ 9999	1000	×
F21.36	feed forward gain	0.000 ~ 7.000	1.000	△
F21.27	Feedforward filtering time	0.000 ~ 7.000s	0.001s	△
F21.38	Position offset change rate	0 ~ 9999	800	×
F22 Group:Virtual IO				
F22.00	Function selection of virtual VDI1 terminal	The same as function code F04.00	0	×
F22.01	Function selection of virtual VDI2 terminal	The same as function code F04.00	0	×
F22.02	Function selection of virtual VDI3 terminal	The same as function code F04.00	0	×
F22.03	Function selection of virtual VDI4 terminal	The same as function code F04.00	0	×
F22.04	Function selection of virtual VDI5 terminal	The same as function code F04.00	0	×
F22.05	Valid status setting mode of virtual VDI terminals	VDI5, VDI4, VDI3, VDI2, VDI1	00000	×
		0: Validity of VDI depends on virtual VDOx's status		
		1: Validity of VDI set by function code F22.06		
F22.06	Settings of virtual VDI terminal status	VDI5, VDI4, VDI3, VDI2, VDI1	00000	△
		0: Invalid		
		1: Valid		
F22.07	Function selection of virtual VDO1 terminals output	0 : Internal short circuited to physics DIx Other: The same as function code F05.00	0	△
F22.08	Function selection of virtual VDO2 terminals output	0 : Internal short circuited to physics DIx Other: The same as function code F05.00	0	△
F22.09	Function selection of virtual VDO3 terminals output	0 : Internal short circuited to physics DIx Other: The same as function code F05.00	0	△
F22.10	Function selection of virtual VDO4 terminals output	0 : Internal short circuited to physics DIx Other: The same as function code F05.00	0	△
F22.11	Function selection of virtual VDO5 terminals output	0 : Internal short circuited to physics DIx Other: The same as function code F05.00	0	△
F22.12	Virtual VDO1 output delay time	0.0s~6000.0s	0.0s	△
F22.13	Virtual VDO2 output delay time	0.0s~6000.0s	0.0s	△

Param.	Parameter Name	Setting Range	Default	Attr
F22.14	Virtual VDO3 output delay time	0.0s~6000.0s	0.0s	△
F22.15	Virtual VDO4 output delay time	0.0s~6000.0s	0.0s	△
F22.16	Virtual VDO5 output delay time	0.0s~6000.0s	0.0s	△
F22.17	VDO output terminal positive and negative logic	VDO5, VDO4, VDO3, VDO2, VDO1	00000	△
		0: Positive logic 1: Negative logic		
Group U00 Status Monitoring				
U00.00	Running frequency	0.00 ~ Fup	0.00Hz	○
U00.01	Set frequency	0.00 ~ Fmax	0.00Hz	○
U00.02	Output voltage	0 ~ 660V	0.0V	○
U00.03	Output current	0.0 ~ 3000.0A	0.0A	○
U00.04	Output power	-3000.0 ~ 3000.0kW	0.0kW	○
U00.05	Estimated Motor Speed	0 ~ 60000rpm	0rpm	○
U00.06	Bus voltage	0 ~ 1200V	0V	○
U00.07	Synchronous Frequency	0.00 ~ Fup	0.00Hz	○
U00.08	PLC step	1 ~ 15	1	○
U00.09	Program Operation Time	0.0 ~ 6000.0s(h)	0.0s(h)	○
U00.10	PID set	0 ~ 60000	0	○
U00.11	PID feedback	0 ~ 60000	0	○
U00.12	Status of DI1 ~ DI5 digital input terminal	DI5 DI4 DI3 DI2 DI1	00000	○
U00.13	Status of DI6 ~ DI7 digital input terminal	DI7 DI6	00	○
U00.14	Status of digital output terminal	R3 R2 R1 Y2 Y1	00000	○
U00.15	AI1 input	0.0 ~ 100.0%	0.0%	○
U00.16	AI2 input	0.0 ~ 100.0%	0.0%	○
U00.17	AI3 input	-100.0 ~ 100.0%	0.0%	○
U00.18	Keypad potentiometer input	0.0 ~ 100.0%	0.0%	○
U00.19	HI input	0.00 ~ 100.00kHz	0.00kHz	○
U00.20	AO1 output	0.0 ~ 100.0%	0.0%	○
U00.21	AO2 output	0.0 ~ 100.0%	0.0%	○
U00.22	HO output	0.00 ~ 100.00kHz	0.00kHz	○
U00.23	Temperature of inverter	-40.0°C ~ 120.0°C	0.0°C	○

Param.	Parameter Name	Setting Range	Default	Attr
U00.24	Accumulative power-on time	0 ~ 65535min	0min	○
U00.25	Accumulative running time	0 ~ 6553.5min	0.0min	○
U00.26	Cumulative power-on time	0 ~ 65535h	0h	○
U00.27	Cumulative running time	0 ~ 65535h	0h	○
U00.28	Count value	0 ~ 65535	0	○
U00.29	Length value	0 ~ 65535m	0m	○
U00.30	Linear speed	0 ~ 65535m/min	0m/Min	
U00.31	Output torque	0.0 ~ 300.0%	0.0%	○
U00.32	PTC motor temperature detection	-40°C ~ 200°C	0°C	○
U00.33	Speed that detected by encoder	0 ~ 60000rpm	0rpm	○
U00.34	Monitoring of encoder line number	0 ~ 65535	0	○
U00.35	Power consumption	0 ~ 65535kWh	0kWh	○
U00.36	VDI1 ~ VDI5 input status	VDI5 VDI4 VDI3 VDI2 VDI1	00000	○
U00.37	VDO1 ~ VDO5output status	VDO5 VDO4 VDO3 VDO2 VDO1	00000	○
U00.38	High speed pulse X7 or the line number of extension card monitoring	0 ~ 65535	0	○
U00.39	Sine cosine encoder C signal	0 ~ 4096	0	○
U00.40	Sine cosine encoder D signal	0 ~ 4096	0	○
U00.41	UVW encoder UVW signal	U V W	000	○
U00.42	Output excitation ratio	0.0 ~ 100.0%	0.0%	○
U00.43	Output torque	0.0 ~ 6553.5 N.m	0.0 N.m	○
Group U01 Fault Record				
U01.00	Code of the latest fault	Err00~Err44	0	○
U01.01	Running frequency when the latest fault occurred	0.00 ~ Fup	0.00Hz	○
U01.02	Output current when the latest fault occurred	0.0 ~ 3000.0A	0.0A	○
U01.03	Bus voltage when the latest fault occurred	0 ~ 1200V	0V	○
U01.04	Cumulative running time when the latest fault occurred	0 ~ 65535h	0h	○
U01.05	Code of previous fault	Same as U01.00	0	○
U01.06	Running frequency when previous fault occurred	0.00 ~ Fup	0.00Hz	○

Param.	Parameter Name	Setting Range	Default	Attr
U01.07	Output current when previous fault occurred	0.0 ~ 3000.0A	0.0A	○
U01.08	Bus voltage when previous fault occurred	0 ~ 1200V	0V	○
U01.09	Cumulative running time when previous fault occurred	0 ~ 65535h	0h	○
U01.10	Before-previous fault code	Same as U01.00	0	○
U01.11	Running frequency when before-previous fault occurred	0.00 ~ Fup	0.00Hz	○
U01.12	Output current when before-previous fault occurred	0.0 ~ 3000.0A	0.0A	○
U01.13	Bus voltage when before-previous fault occurred	0 ~ 1200V	0V	○
U01.14	Cumulative running time when before-previous fault occurred	0 ~ 65535h	0h	○
U01.15	Previous 3 categories of faults	The same with U01.00	Err00	○
U01.16	Previous 4 categories of faults	The same with U01.00	Err00	○
U01.17	Previous 5 categories of faults	The same with U01.00	Err00	○
U01.18	Previous 6 categories of faults	The same with U01.00	Err00	○
U01.19	Previous 7 categories of faults	The same with U01.00	Err00	○
U01.20	Previous 8 categories of faults	The same with U01.00	Err00	○
U01.21	Previous 9 categories of faults	The same with U01.00	Err00	○
U01.22	Previous 10 categories of faults	The same with U01.00	Err00	○
U01.23	Previous 11 categories of faults	The same with U01.00	Err00	○
U01.24	Previous 12 categories of faults	The same with U01.00	Err00	○
U01.25	Previous 13 categories of faults	The same with U01.00	Err00	○

Chapter 5 Maintenance and Troubleshooting

FR30 inverter provides a number of warning information and protection, when a fault occurs, the protective function is activated, the inverter will stop output, inverter fault relay contact, and in the inverter displays the fault code on the display panel. Before seeking service user can press the self-examination tips in this section, analyze problems, and identify solutions. If the problem still cannot be excluded, seek services, or contact the dealer you purchase the drive with my company.

Display	Fault Name	Possible Causes	Solutions
Err01	Accel overcurrent	1: The output circuit is grounded or short circuited. 2: The acceleration time is too short. 3: Manual torque boost or V/F curve is not appropriate. 4: The voltage is too low. 5: The startup operation is performed on the rotating motor. 6: A sudden load is added during acceleration. 7: The AC drive model is of too small power class.	1: Eliminate external faults. 2: Increase the acceleration time. 3: Adjust the manual torque boost or V/F curve. 4: Adjust the voltage to normal range. 5: Select rotational speed tracking restart or start the motor after it stops. 6: Remove the added load. 7: Select an AC drive of higher power class
Err02	Decel overcurrent	1: The output circuit is grounded or short circuited. 2: The deceleration time is too short. 3: The voltage is too low. 4: A sudden load is added during deceleration. 5: The braking unit and braking resistor are not installed.	1: Eliminate external faults. 2: Increase the deceleration time. 3: Adjust the voltage to normal range. 4: Remove the added load. 5: Install the braking unit and braking resistor.
Err03	Constant-speed overcurrent	1: The output circuit is grounded or short circuited. 2: The voltage is too low. 3: A sudden load is added during operation. 4: The AC drive model is of too small power class.	1: Eliminate external faults 2: Adjust the voltage to normal range. 3: Remove the added load 4: Select an AC drive of higher power class.
Err04	Accel overvoltage	1: The input voltage is too high. 2: An external force drives the motor during acceleration. 3: The acceleration time is too short. 4: The braking unit and braking resistor are not installed.	1: Adjust the voltage to normal range. 2: Cancel the external force or install a braking resistor. 3: Increase the acceleration time. 4: Install the braking unit and braking resistor.
Err05	Decel overvoltage	1: The input voltage is too high. 2: An external force drives the motor during deceleration. 3: The deceleration time is too short. 4: The braking unit and braking resistor are not installed.	1: Adjust the voltage to normal range. 2: Cancel the external force or install the braking resistor. 3: Increase the deceleration time. 4: Install the braking unit and braking resistor.

Display	Fault Name	Possible Causes	Solutions
Err06	Constant-speed overvoltage	1: The input voltage is too high 2: An external force drives the motor during deceleration.	1: Adjust the voltage to normal range. 2: Cancel the external force or install the braking resistor.
Err07	Bus undervoltage	1: Instantaneous power failure occurs on the input power supply. 2: The AC drive's input voltage is not within the allowable range. 3: The bus voltage is abnormal. 4: The rectifier bridge and buffer resistor are faulty. 5: The drive board is faulty. 6: The main control board is faulty.	1: Reset the fault. 2: Adjust the voltage to normal range. 3: Contact the agent or Frecon.
Err08	Short circuit	1: The output circuit is grounded or short circuited. 2: The connecting cable of the motor is too long. 3: The module overheats. 4: The internal connections become loose. 5: The main control board is faulty 6: The drive board is faulty. 7: The inverter module is faulty.	1: Eliminate external faults. 2: Install a reactor or an output filter. 3: Check the air filter and the cooling fan. 4: Connect all cables properly. 5: Contact the agent or Frecon.
Err09	Power input phase loss	1: The three-phase power input is abnormal. 2: The drive board is faulty. 3: The lightning board is faulty. 4: The main control board is faulty.	1: Eliminate external faults. 2: Contact the agent or FRECON.
Err10	Power output phase loss	1: The cable connecting the AC drive and the motor is faulty. 2: The AC drive's three-phase outputs are unbalanced when the motor is running. 3: The drive board is faulty. 4: The module is faulty.	1: Eliminate external faults. 2: Check whether the motor Three-phase winding is normal. 3: Contact the agent or Frecon.
Err11	Motor overload	1: F11-17 is set improperly. 2: The load is too heavy or locked-rotor occurs on the motor. 3: The AC drive model is of too small power class.	1: Set F11-17 correctly. 2: Reduce the load and check the motor and the mechanical condition. 3: Select an AC drive of higher power class.
Err12	Inverter overload	1: The load is too heavy or locked-rotor occurs on the motor. 2: The AC drive model is of too small power class.	1: Reduce the load and check the motor and mechanical condition. 2: Select an AC drive of higher power class.

Display	Fault Name	Possible Causes	Solutions
Err13	External equipment fault	1: External fault signal is input via DI.	Reset the operation.
Err14	Module overheat	1: The ambient temperature is too high. 2: The air filter is blocked. 3: The fan is damaged. 4: The thermally sensitive resistor of the module is damaged. 5: The inverter module is damaged.	1: Lower the ambient temperature. 2: Clean the air filter. 3: Replace the damaged fan. 4: Replace the damaged thermally sensitive resistor. 5: Replace the inverter module.
Err15	EEPROM read/write fault	The EEPROM chip is damaged.	Replace the main control board.
Err16	Motor auto-tuning cancelled	Since the identification process, press STOP / RST key	Press STOP / RST key to reset
Err17	Motor auto-tuning fault	1: the motor and the inverter output terminals are not connected 2: The motor does not disengage the load 3: The electrical fault	1: check the connection between the inverter and motor 2: The motor is disengaged load 3: Check the motor
Err18	Communication overtime error	1: The PC is not working properly 2: The communication line is not normal 3: F15 set communication parameters set incorrectly	1: Check the PC Connection 2: Check the communication cable 3: The communication parameters are set correctly
Err19	PID feedback loss	PID feedback set value is less than F13.24	Check the PID feedback signal or set to an appropriate value F13.24
Err20	Continuous running time reached	Set the running time to reach this function	reference F05.14 Description
Err21	Parameter upload fault	1: Is not installed or is not plugged parameter copy card 2: Parameter copy card anomalies 3: The control board abnormalities	1: a copy of the card is properly installed parameters 2: for technical support 3: for technical support
Err22	Parameter download fault	1: Is not installed or is not plugged parameter copy card 2: Parameter copy card anomalies 3: The control board abnormalities	1: A copy of the card is properly installed parameters 2: For technical support 3: For technical support
Err23	Braking unit fault	1: The brake line failure or damage the brake pipe 2: An external braking resistor is too small	1: Check the brake unit, replace the brake pipe 2: Increasing the braking resistor

Display	Fault Name	Possible Causes	Solutions
Err24	Module temperature detection disconnection	The temperature sensor failure or cable break	For technical support
Err25	Load becoming 0	The AC drive running current is lower than F11.22	Check that the load is disconnected or the setting F11-22 and F11-23 is correct.
Err26	With-wave current limit fault	1: The load is too heavy or locked rotor occurs on the motor. 2: The AC drive model is of too small power class.	1: Reduce the load and check the motor and mechanical condition. 2: Select an AC drive of higher power class.
Err27	Inverter soft-start relay is off	1: The grid voltage is too low 2: Rectifier module failure	1: Check the grid voltage 2: Demand for technical support
Err28	Software version compatibility fault	1: The upper and lower transmission module parameters in the parameter version of the control panel mismatch.	re-upload module parameters to pass down
Err29	Instantaneous overcurrent	1. Inverter output circuit being grounded or short-circuit; 2. The acceleration and deceleration time is too short; 3. Manually torque boost or V/F curve not appropriate; 4. Voltage too low; 5. Start the running motor; 6. Sudden-load in the acceleration process; 7. Model selection of inverter power is too small.	1. Troubleshooting peripheral problems; 2. To increase the acceleration time; 3. Adjust the manually torque boost or V/F curve; 4. Adjust the voltage to normal range; 5. Select RPM track start or start after motor stopped; 6. Cancel sudden-load; 7. Select the inverter with larger power.
Err30	Instantaneous overvoltage	1: Input voltage is too high; 2. There is external force drag the motor to run in deceleration process; 3. The deceleration time is too short; 4. No installation of braking resistor.	1: Adjust the voltage to normal range; 2. Cancel external force or install brake resistor; 3. To increase the deceleration time; 4. Install braking resistor
Err36	PG card is disconnection (close loop)	PG card detects that the encoder signal is disconnected	Check the cable of encoder
Err37	Over Speed (close loop)	1. Encoder parameters not right 2. F11.41 and F11.42 not unreasonable. 3. No parameter tuning	1. check encoder parameters 2. check the value of F11.41 and F11.42 3. Perform parameter tuning

Err38	Excessive speed deviation (close loop)	<ol style="list-style-type: none"> 1. Motor Locked Rotor 2. Encoder parameters not right 3. F11.43 and F11.44 not unreasonable. 4. Output circuit is abnormal 	<ol style="list-style-type: none"> 1. check encoder parameters 2. check the value of F11.43 and F11.44 3. check drive output circuit
Err39	Motor temperature too high	<ol style="list-style-type: none"> 1, PTC sensor configuration not right 2, Motor temperature protection value too small 3, Motor temperature too high 	<ol style="list-style-type: none"> 1, Reset PTC sensor parameter 2, Increase motor temperature protection value 3, Waiting until motor is cooled
Err40	The setting running time ends	<ol style="list-style-type: none"> 1, Running time more than F00.25 	<ol style="list-style-type: none"> 1. Contact the dealer
Err41	Overload warning	<ol style="list-style-type: none"> 1, when F11.18 = 00100 and the current output amp is more than F11.19 	<ol style="list-style-type: none"> 1, Check the current load
Err44	Short circuit to ground	When the ten's place of F02.04 is set and the drive output is circuited to the ground.	<ol style="list-style-type: none"> 1. Check the value of F02.04 and the output circuit of drive
Err45	Dry pumping fault (multi-pump constant pressure water supply special machine)	<ol style="list-style-type: none"> 1. The water supply source is dry 	<ol style="list-style-type: none"> 1. Check the water source
Err46	STO fault 1	<ol style="list-style-type: none"> 1. STO1 is activated, and STO2 is normal 2. STO2 is activated, and STO1 is normal 3. STO1 and STO2 are activated at the same time 	<ol style="list-style-type: none"> 1. Check whether STO1 and STO2 have 24VDC inputs 2. Check whether the positive and negative polarities of STO1 or STO2 24VDC input are reversed 3. Seek technical support
Err47	STO fault 2	<ol style="list-style-type: none"> 1. STO supply voltage is abnormal 2. STO-L pulse optocoupler self-test is abnormal 3. STO-Buffer self-test is abnormal 4. The STO-RAM self-test is abnormal 5. STO-FLASH self-test is abnormal 	<ol style="list-style-type: none"> 1. Check whether the power supply is normal 2. Seek technical support

Appendix A: Modbus Communication Protocol

Application Scope

1. Applicable series: FRECON FR series inverter.
 2. Applicable network: Support Modbus protocol, RTU format, with single-master/multi-slave Communication network of RS485 bus.
- The typical RTU message frame format:

Start Bit	Device Address	Function Code	Data	CRC	Stop Bit
T1-T2-T3-T4	8Bit	8Bit	n*8Bit	16Bit	T1-T2-T3-T4

2. Physical Interface

RS485 is asynchronous half-duplex Communication mode. LSB has transmission priority.

Default data format of RS485 terminal: 1-8-N-1, bits rate: 9600bps.

Data format 1-8-N-1, 1-8-O-1, 1-8-E-1, optional bits rates 4800bps, 9600bps, 19200bps, 38400bps, 57600bps and 115200bps can be selected.

Shielded twisted-pair cable is recommended Communication cable to lower external interference.

3. Protocol Format

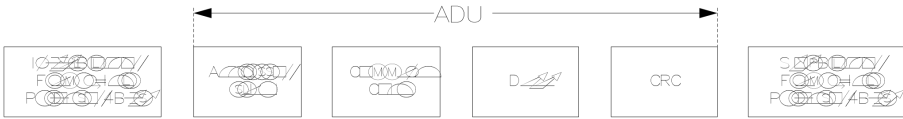

The parity in ADU (Application Data Unit) is obtained via the CRC16 parity of the 1st three Parts of ADU and switch the low bytes and high bytes. Low bytes of CRC parity go first, and high bytes of it follow in the protocol format.

4. Description of Protocol Format

4.1 Address Code

Address of slave inverter. The setting range: 1 ~ 247, 0 is broadcast address.

4.2 Command Code

Command Code	Function
03H	Read parameters and status byte of inverter
06H	Write single function code or control parameter of inverter
08H	Circuit diagnosis and setting

name	Description
Function Code (F00.00 ~ U01.99)	<p>High byte function code group number, F00 ~ F31, U00, U01, respectively, corresponding to the high byte address is 00H ~ 1FH, 30H, 31H.</p> <p>Low byte of the group function code number, from 0 to 99 corresponding to the low byte address is 00H ~ 63H.</p> <p>For example: Modify F01.02 function code value, no power-down when storing the corresponding register address (referred to as RAM address) to 0102H. EEPROM is frequently modified, will reduce the life of the EEPROM. If you modify the value of the function code-down storage needs, you can make this function code is the highest position a high address. Note that this address is only to write, not read.</p> <p>For example: Modify F01.02 function code value, and the corresponding need to power down when storing the register address (referred to as EEPROM address) to 8102H.</p>

4.3 Allocation of Register Addresses

Function code group	RAM address high byte	EEPROM address high byte
F00	0x00	0x80
F01	0x01	0x81
F02	0x02	0x82
F03	0x03	0x83
F04	0x04	0x84
F05	0x05	0x85
F06	0x06	0x86
F07	0x07	0x87
F08	0x08	0x88
F09	0x09	0x89
F10	0x0A	0x8A
F11	0x0B	0x8B
F12	0x0C	0x8C
F13	0x0D	0x8D
F14	0x0E	0x8E
F15	0x0F	0x8F
F16	0x10	0x90
F17	0x11	0x91
F18	0x12	0x92
F19	0x13	0x93
F20	0x14	0x94
F21	0x15	0x95
F22	0x16	0x96
U00 (Read Only)	0x30	--
U01 (Read Only)	0x31	--

4.4 Address and control command functions: (write only)

Command word address	Command Function
2000H	0001: Forward run 0002: Reverse Run 0003: Inching Forward 0004: Reverse Jog 0005: Slowdown stop 0006: Freewheel 0007: Fault reset
2001H	Communication setting frequency (0 ~ Fmax (Unit: 0.01Hz))
2002H	PID given range (0 to 1000, 1000 corresponds to 100.0%)
2003H	PID feedback range (0 ~ 1000, 1000 corresponds to 100.0%)
2004H	Torque set point (-3000 ~ 3000, 1000 corresponds to 100.0% motor rated current)
2005H	AO output 1 (0~1000 corresponds to 0~100.0%)
2006H	AO output 2 (0~1000 corresponds to 0~100.0%)
2007H	DO output control Bit0: Y1 Bit1: Y2 Bit2: R1 Bit3: R2 Bit4~Bit15: Reserved

4.5 The status and function of the read address Description: (read only)

Status word address	functional status word
2100H	0000H: parameter setting 0001H: slave run 0002H: JOG operation 0003H: learning run 0004H: Slave parking 0005H: JOG parking 0006H: Fault Status
2101H	Bit0: 0 are given effective 1 Given negative effective Bit1:0 frequency output Forward 1 frequency output inversion Bit2 ~ 3: 00 Keyboard start-stop 01 terminal start-stop 10 start-stop communication 11 Reserved Bit4: 0 Factory password is invalid 1 factory password is valid Bit5: 0 user password is invalid 1 valid user password Bit6 ~ 7: 00 basic function code group 01 user-defined function code group 10 different functions with the factory default code group 11 Others
2102H	The current fault type of the inverter
2103H	The current warning type of the frequency converter

5 Illustration

1, No. 01 reads the output frequency value (U00.00), returned 5000, that 50.00Hz.

To send data:

01 03 30 00 00 01 8B 0A

The received data is:

01 03 02 13 88 B5 12

2, No. 01 Drive communication given frequency 30.00Hz, send the data content of 3000.

To send data:

01 06 20 01 0B B8 D4 88

The received data is:

01 06 20 01 0B B8 D4 88

3, communications sent on the 1st drive forward run command, write to the address 2000H 01

To send data:

01 06 20 00 00 01 43 CA

The received data is:

01 06 20 00 00 01 43 CA

4, No. 01 communications sent inverter deceleration stop command, the address to write to 2000H 05

To send data:

0106200000054209

The received data is:

0106200000054209

Appendix B: Braking Resistor

When the inverter with large inertia load deceleration or need to slow down sharply, the motor will be in the power generation state, the load energy through the inverter bridge to the inverter DC link, causing the inverter bus voltage rise, when more than a certain value, the inverter will report overvoltage fault, and even lead to the inverter internal power module overvoltage damage, in order to prevent the occurrence of this phenomenon, must be configured with brake components.

The following is the recommended brake resistor power and resistance value. According to the load situation, the user can change the value appropriately, but it must be within the recommended range.

Inverter Model No.	Brake unit		125% braking torque (10% ED, 10 sec max)		inimum enabled brake resistance		
	Model	quantity	Recommended brake resistance specifications	Number of brake resistors			
FR30-4T-0.7B-H	Standard built-in	1	200W 600Ω	1	100Ω		
FR30-4T-1.5B-H			300W 360Ω	1	100Ω		
FR30-4T-2.2B-H			300W 180Ω	1	100Ω		
FR30-4T-3.0B-H			300W 180Ω	1	100Ω		
FR30-4T-4.0B-H			400W 150Ω	1	100Ω		
FR30-4T-5.5B-H			600W 100Ω	1	80Ω		
FR30-4T-7.5B-H			800W 75Ω	1	60Ω		
FR30-4T-011B-H			1.1kW 50Ω	1	43Ω		
FR30-4T-015B-H			1.6kW 40Ω	1	31Ω		
FR30-4T-018B-H			4.0kW 32Ω	1	24Ω		
FR30-4T-022B-H			4.5kW 27Ω	1	24Ω		
FR30-4T-030B-H			6.0kW 20Ω	1	19.2Ω		
FR30-4T-037(B)-H			Built-in optional	1	7.0kW 20Ω	1	19.2Ω
FR30-4T-045(B)-H					9.0kW 13Ω	1	12.8Ω
FR30-4T-055(B)-H	11.0kW 10.2Ω	1			9.6Ω		
FR30-4T-075(B)-H	15.0kW 7.5Ω	1			6.8Ω		
FR30-4T-090(B)-H	18.0kW 6.5Ω	1			6.3Ω		
FR30-4T-110(B)-H	26.0kW 6Ω	1			6Ω		
FR30-4T-132-H	FRBU-4 T-315	1	26.0kW 4Ω	1	4Ω		
FR30-4T-160-H			26.0kW 4Ω	1	4Ω		

Note: The wire should be above voltage-resistant AC450V and temperature-resistant 105°C.

Appendix C: Peripheral Device Selection

Inverter Model No.	Circuit breaker (A)	Contactor (A)	Power terminal cable specification smm ²	Grounding terminal cable specification smm ²	Terminal screw specifications
Three-phase power supply: 380V, 50/60Hz Range: -15%~+30%					
FR30-4T-0.7B-H	10	10	2.5	2.5	M4
FR30-4T-1.5B-H	16	10	2.5	2.5	M4
FR30-4T-2.2B-H	16	10	2.5	2.5	M4
FR30-4T-3.0B-H	16	10	2.5	2.5	M4
FR30-4T-4.0B-H	25	16	4.0	4.0	M4
FR30-4T-5.5B-H	32	25	4.0	4.0	M4
FR30-4T-7.5B-H	40	32	4.0	4.0	M4
FR30-4T-011B-H	63	40	6.0	6.0	M4
FR30-4T-015B-H	63	40	6.0	6.0	M5
FR30-4T-018B-H	100	63	10	10	M5
FR30-4T-022B-H	100	63	10	10	M5
FR30-4T-030B-H	100	63	16	10	M6
FR30-4T-037(B)-H	160	100	16	16	M8
FR30-4T-045(B)-H	200	125	25	16	M8
FR30-4T-055(B)-H	200	125	35	25	M8
FR30-4T-075(B)-H	250	160	50	25	M8
FR30-4T-090(B)-H	250	160	70	35	M8
FR30-4T-110(B)-H	350	350	120	60	M10
FR30-4T-132-H	400	400	150	75	M10
FR30-4T-160-H	500	400	185	95	M10

Appendix D: Keyboard Dimensions

LCD keyboard size:

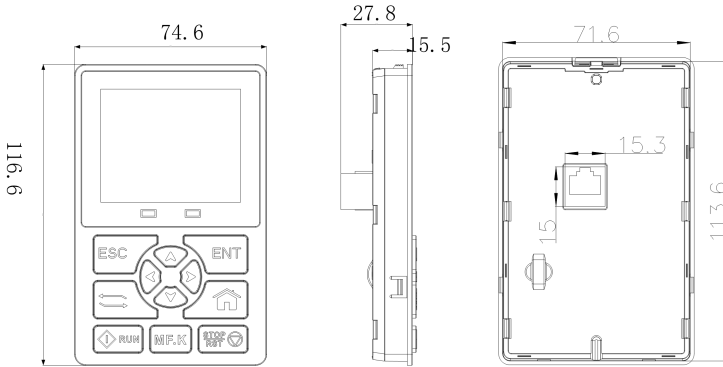

External keyboard installation:

External keyboard installation instructions: first open the mounting panel according to the size shown in Figure 2-9 according to the power range of the machine, and then card the keyboard tray into the mounting panel and then load the keyboard assembly into the keyboard tray. (When removing the keyboard tray, please first take out the keyboard first, and then take it out according to the illustration)

